

Horizons

Volume 38, Issue 1

AIAA Houston Section www.aiaahouston.org
The American Institute of Aeronautics and Astronautics

July / August 2012

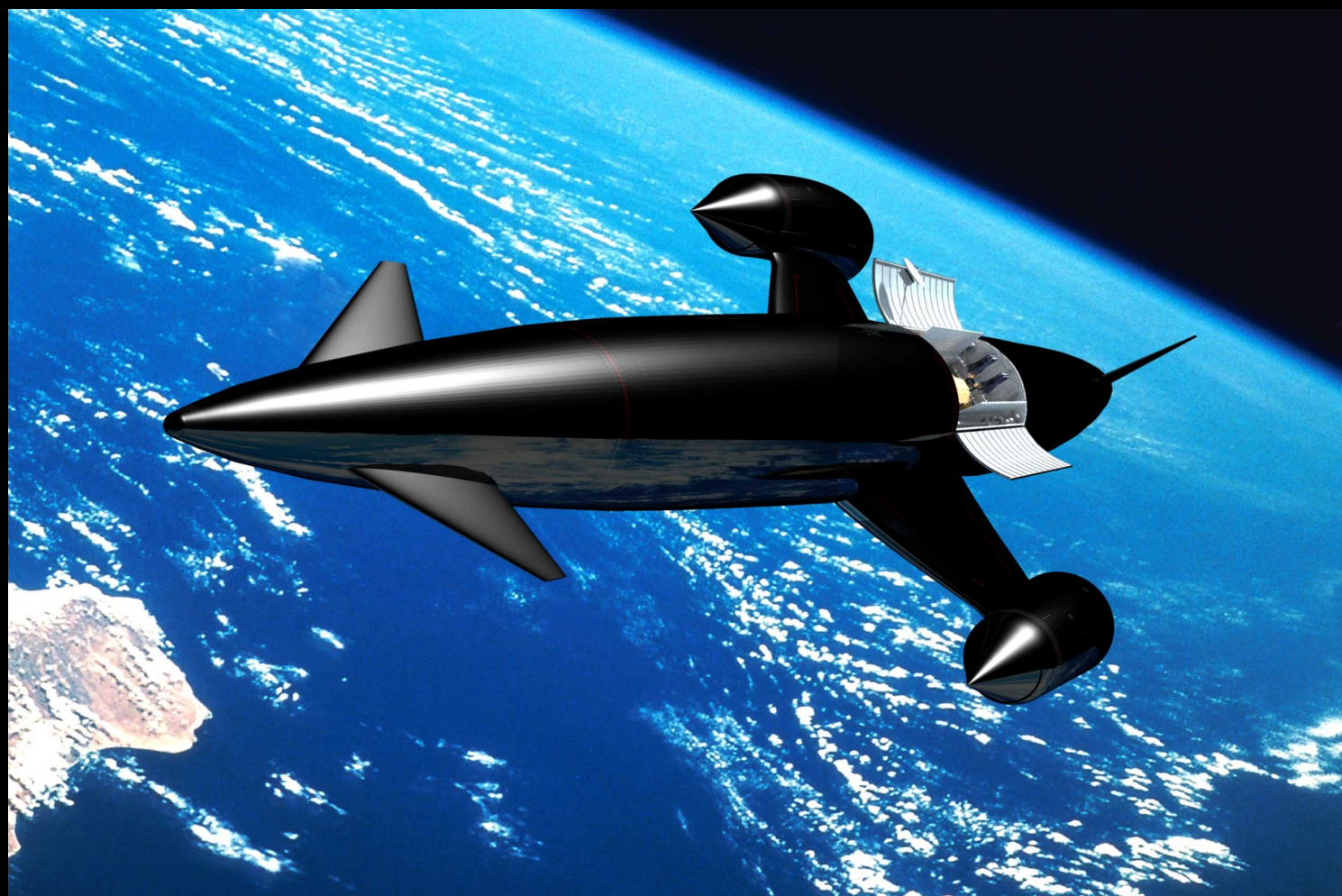



AIAA HOUSTON
American Institute of Aeronautics and Astronautics

Horizons is a bimonthly publication of the Houston Section of the American Institute of Aeronautics and Astronautics.

Douglas Yazell
Editor

Past Editors: Dr. Steven E. Everett
Editing team: Don Kulba, Ellen Gillespie, Robert Beremand, Alan Simon, Dr. Steven Everett, Shen Ge
Regular contributors: Dr. Steven Everett, Don Kulba, Philippe Mairet, Alan Simon, Scott Lowther
Contributors this issue: Dr. Jon B. Olansen, Sean Carter, Raphael Munoz, Michael Frostad

**AIAA Houston Section
Executive Council**

Sean Carter
Chair

Daniel Nobles
Chair-Elect

Irene Chan
Secretary

Sarah Shull
Past Chair

John Kostrzewski
Treasurer

Julie Read
Vice-Chair, Operations

Alan Sisson
Dr. Satya Pilla
Vice-Chair, Technical

Operations

Dr. Gary Turner
Shen Ge
Melissa Gordon
Lisa Voiles
Rafael Munoz
Svetlana Hanson
Michael Frostad
Dr. Benjamin Longmier
Matthew Easterly
Douglas Yazell
Gary Cowan
Joel Henry

Technical

Dr. Albert A. Jackson IV
Bebe Kelly-Serrato
Dr. Zafar Taqvi
Bill Atwell
Sheikh Ahsan
William West
Paul Nielson
Dr. Steven E. Everett
Gary Brown
Dr. Kamlesh Lulla
Ludmila Dmitriev-Odier

Councilors

Ellen Gillespie
Brian Banker
Matt Johnson
Clay Stangle
Melissa Kronenberger
Sarah Barr
Donald Barker
Shirley Brandt
Holly Feldman
Gabe Garrett

www.aiaahouston.org

July / August 2012



TABLE OF CONTENTS

From the Chair 3
From the Editor 4
Cover Story: 5

The 1940 Air Terminal Museum at Hobby Airport 13
50th Anniversary audio files

Ellington Field, Airport, Spaceport & The Lone Star Flight Museum

The Experimental Aircraft Association (EAA) Chapter 12 (Houston)
(APR by Scott Lowther)

AIAA Conference Papers by AIAA Houston Section Members

Current Events

Staying Informed

Calendar

Cranium Cruncher by Dr. Steven E. Everett

Section News

The Back Cover: 36

Horizons and AIAA Houston Section Web Site
AIAA National Communications Award Winner



This newsletter is created by members of AIAA Houston Section. Opinions expressed herein other than by elected Houston Section officers belong solely to the authors and do not necessarily represent the position of AIAA or the Houston Section. Unless explicitly stated, in no way are the comments of individual contributors to Horizons to be construed as necessarily the opinion or position of AIAA, NASA, its contractors, or any other organization. All articles in Horizons, unless otherwise noted, are the property of the individual contributors. Reproduction/republishing in any form except limited excerpts with attribution to the source, will require the express approval of the individual authors. Please address all newsletter correspondence to editor-in-chief[at]aiaa-houston.org.

Cover:

From the Editor

Skylon & New Section Logos

DOUGLAS YAZELL, EDITOR

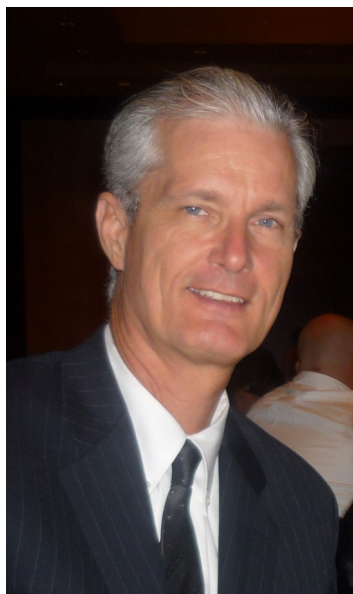

The logo below for AIAA Houston Section is new, thanks to Webmaster Irene Chan. She took some ideas from Alan Sisson, Michael Frostad and me and hit a home run with two designs.

Her second logo design is shown on the back cover. We need letterheads using these logos, and we need these logos in various colors and resolutions, but these are great candidates for our final de-

signs. Irene kept in touch with Sara Bluestone at AIAA, as recommended in the AIAA branding & logos manual, so these two designs respect the official guidelines.



E-mail:
[editor2012\[at\]aiaahouston.org](mailto:editor2012[at]aiaahouston.org)

For a Horizons archive on a national AIAA web site click [here](#).

www.aiaahouston.org



Skylon

GEORGE W. S. ABBEY, JR.

Cover Story

About 500 words per page for about five pages, and seven pages are shown here in a planned 36-page issue of Horizons, the bimonthly newsletter of AIAA Houston Section (The American Institute of Aeronautics and Astronautics). Horizons is a free download using PDF format. It is typically 36 pages and 10 to 15 MB per issue. Circulation is about 400 downloads per issue, but in 2007 one issue had more than 30,000 downloads (cover story: The DIRECT Approach). A year or two earlier, one issue had over 40,000 downloads (cover story: Open Source and Free Software). Deadline for inputs for this July / August 2012 issue: August 10, 2012. This issue will be online and publicized by August 31, 2012. The web site will be www.aiaa-houston.org until June 30, 2012, then we are changing everything and us-

ing www.aiaahouston.org. The following paragraphs repeat this paragraph.

About 500 words per page for about five pages, and seven pages are shown here in a planned 36-page issue of Horizons, the bimonthly newsletter of AIAA Houston Section (The American Institute of Aeronautics and Astronautics). Horizons is a free download using PDF format. It is typically 36 pages and 10 to 15 MB per issue. Circulation is about 400 downloads per issue, but in 2007 one issue had more than 30,000 downloads (cover story: The DIRECT Approach). A year or two earlier, one issue had over 40,000 downloads (cover story: Open Source and Free Software). Deadline for inputs for this July / August 2012 issue: August 10, 2012. This issue will be

online and publicized by August 31, 2012. The web site will be www.aiaa-houston.org until June 30, 2012, then we are changing everything and using www.aiaahouston.org. The following paragraphs repeat this paragraph.

About 500 words per page for about five pages, and seven pages are shown here in a planned 36-page issue of Horizons, the bimonthly newsletter of AIAA Houston Section (The American Institute of Aeronautics and Astronautics). Horizons is a free download using PDF format. It is typically 36 pages and 10 to 15 MB per issue. Circulation is about 400 downloads per issue, but in 2007 one issue had more than 30,000 downloads (cover story: The DIRECT Approach). A year or two earlier, one issue had

(Continued on page 6)

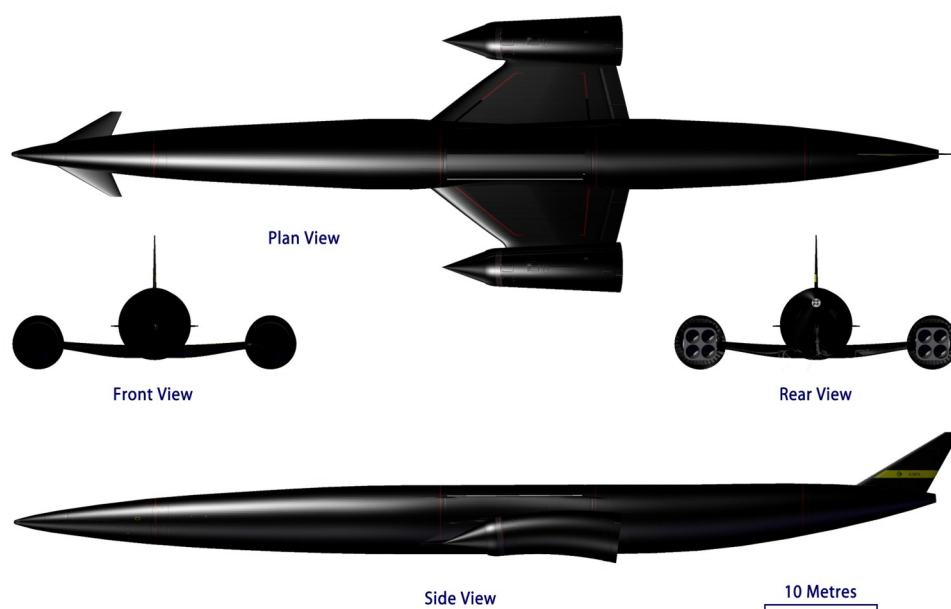

Skylon

(Continued from page 5)
 over 40,000 downloads (cover story: Open Source and Free Software). Deadline for inputs for this July / August 2012 issue: August 10, 2012. This issue will be online and published by August 31, 2012. The web site will be www.aiaa-houston.org until June 30, 2012, then we are changing everything and using www.aiaahouston.org. The following paragraphs repeat this paragraph.

About 500 words per page for about five pages, and seven pages are shown here in a planned 36-page issue of Horizons, the bimonthly newsletter of AIAA Houston Section (The American Institute of Aeronautics and Astronautics). Horizons is a free download using PDF format. It is typically 36 pages and 10 to 15 MB per issue. Circulation is about 400 downloads per issue, but in 2007 one issue had more than 30,000 downloads (cover story: The DIRECT Approach). A year or two earlier, one issue had over 40,000 downloads (cover story: Open Source and Free Software). Deadline for inputs for this July / August 2012

issue: August 10, 2012. This issue will be online and published by August 31, 2012. The web site will be www.aiaa-houston.org until June 30, 2012, then we are changing everything and using www.aiaahouston.org. The following paragraphs repeat this paragraph.

About 500 words per page for about five pages, and seven pages are shown here in a planned 36-page issue of Horizons, the bimonthly newsletter of AIAA Houston Section (The American Institute of Aeronautics and Astronautics). Horizons is a free download using PDF format. It is typically 36 pages and 10 to 15 MB per issue. Circulation is about 400 downloads per issue, but in 2007 one issue had more than 30,000 downloads (cover story: The DIRECT Approach). A year or two earlier, one issue had over 40,000 downloads (cover story: Open Source and Free Software). Deadline for inputs for this July / August 2012 issue: August 10, 2012. This issue will be online and published by August 31, 2012. The web site will be www.aiaa-houston.org until

June 30, 2012, then we are changing everything and using www.aiaahouston.org. The following paragraphs repeat this paragraph.

About 500 words per page for about five pages, and seven pages are shown here in a planned 36-page issue of Horizons, the bimonthly newsletter of AIAA Houston Section (The American Institute of Aeronautics and Astronautics). Horizons is a free download using PDF format. It is typically 36 pages and 10 to 15 MB per issue. Circulation is about 400 downloads per issue, but in 2007 one issue had more than 30,000 downloads (cover story: The DIRECT Approach). A year or two earlier, one issue had over 40,000 downloads (cover story: Open Source and Free Software). Deadline for inputs for this July / August 2012 issue: August 10, 2012. This issue will be online and published by August 31, 2012. The web site will be www.aiaa-houston.org until June 30, 2012, then we are changing everything and using www.aiaahouston.org.

(Continued on page 7)

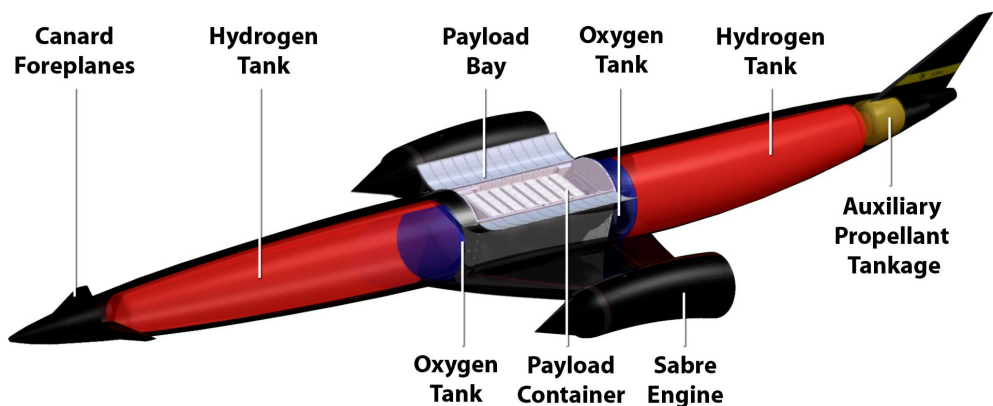

Skylon

(Continued from page 6)

The following paragraphs repeat this paragraph.

About 500 words per page for about five pages, and seven pages are shown here in a planned 36-page issue of Horizons, the bimonthly newsletter of AIAA Houston Section (The American Institute of Aeronautics and Astronautics). Horizons is a free download using PDF format. It is typically 36 pages and 10 to 15 MB per issue. Circulation is about 400 downloads per issue, but in 2007 one issue had more than 30,000 downloads (cover story: The DIRECT Approach). A year or two earlier, one issue had over 40,000 downloads (cover story: Open Source and Free Software). Deadline for inputs for this July / August 2012 issue: August 10, 2012. This issue will be online and publicized by August 31, 2012. The web site will be

www.aiaa-houston.org until June 30, 2012, then we are changing everything and using www.aiaahouston.org. The following paragraphs repeat this paragraph.

About 500 words per page for about five pages, and seven pages are shown here in a planned 36-page issue of Horizons, the bimonthly newsletter of AIAA Houston Section (The American Institute of Aeronautics and Astronautics). Horizons is a free download using PDF format. It is typically 36 pages and 10 to 15 MB per issue. Circulation is about 400 downloads per issue, but in 2007 one issue had more than 30,000 downloads (cover story: The DIRECT Approach). A year or two earlier, one issue had over 40,000 downloads (cover story: Open Source and Free Software). Deadline for inputs for this July / August 2012 issue: August 10, 2012. This

issue will be online and publicized by August 31, 2012.

The web site will be www.aiaa-houston.org until June 30, 2012, then we are changing everything and using www.aiaahouston.org. The following paragraphs repeat this paragraph.

About 500 words per page for about five pages, and seven pages are shown here in a planned 36-page issue of Horizons, the bimonthly newsletter of AIAA Houston Section (The American Institute of Aeronautics and Astronautics). Horizons is a free download using PDF format. It is typically 36 pages and 10 to 15 MB per issue. Circulation is about 400 downloads per issue, but in 2007 one issue had more than 30,000 downloads (cover story: The DIRECT Approach). A year or two earlier, one issue had over 40,000 downloads (cover story: Open Source and Free

(Continued on page 8)

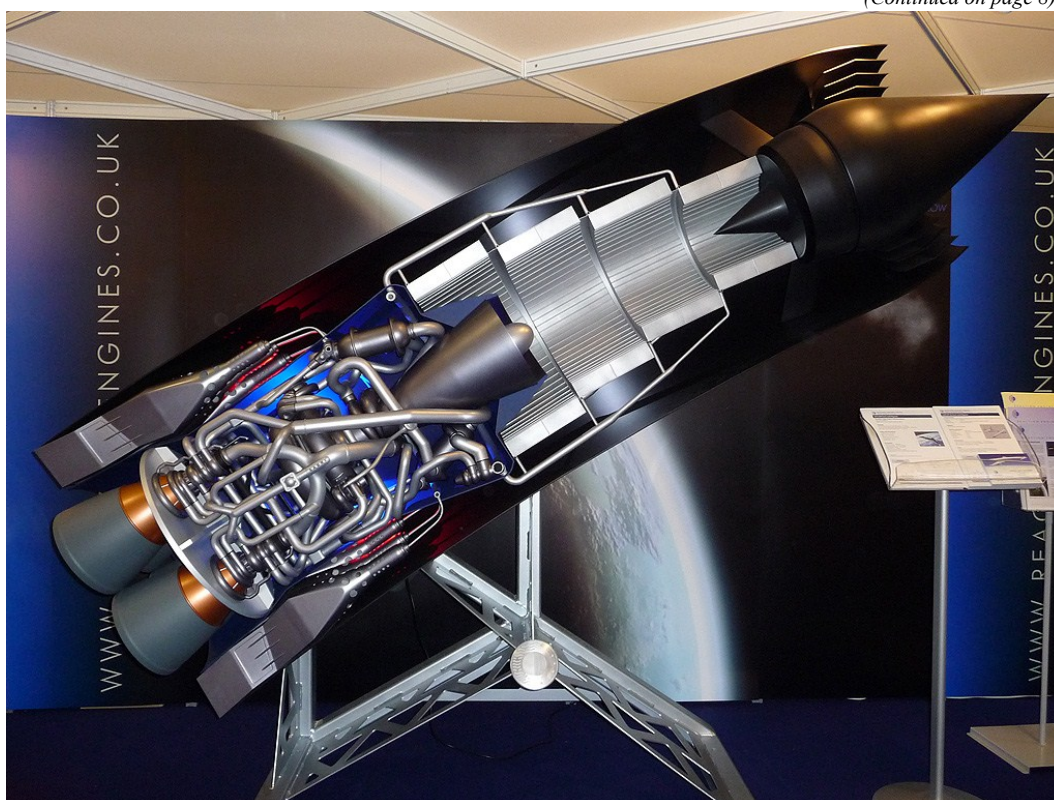

Skylon

(Continued from page 7)
Software). Deadline for inputs for this July / August 2012 issue: August 10, 2012. This issue will be online and published by August 31, 2012. The web site will be www.aiaa-houston.org until June 30, 2012, then we are changing everything and using www.aiaahouston.org. The following paragraphs repeat this paragraph.

About 500 words per page for about five pages, and seven pages are shown here in a planned 36-page issue of Horizons, the bimonthly newsletter of AIAA Houston Section (The American Institute of Aeronautics and Astronautics). Horizons is a free download using PDF format. It is typically 36 pages and 10 to 15 MB per issue. Circulation is about 400 downloads per issue, but in 2007 one issue had more than 30,000 downloads (cover story: The DIRECT Approach). A year or two earlier, one issue had over 40,000 downloads (cover story: Open Source and Free Software). Deadline for inputs for this July / August 2012

issue: August 10, 2012. This issue will be online and published by August 31, 2012. The web site will be www.aiaa-houston.org until June 30, 2012, then we are changing everything and using www.aiaahouston.org. The following paragraphs repeat this paragraph.

About 500 words per page for about five pages, and seven pages are shown here in a planned 36-page issue of Horizons, the bimonthly newsletter of AIAA Houston Section (The American Institute of Aeronautics and Astronautics). Horizons is a free download using PDF format. It is typically 36 pages and 10 to 15 MB per issue. Circulation is about 400 downloads per issue, but in 2007 one issue had more than 30,000 downloads (cover story: The DIRECT Approach). A year or two earlier, one issue had over 40,000 downloads (cover story: Open Source and Free Software). Deadline for inputs for this July / August 2012 issue: August 10, 2012. This issue will be online and published by August 31, 2012.

The web site will be www.aiaa-houston.org until June 30, 2012, then we are changing everything and using www.aiaahouston.org. The following paragraphs repeat this paragraph.

About 500 words per page for about five pages, and seven pages are shown here in a planned 36-page issue of Horizons, the bimonthly newsletter of AIAA Houston Section (The American Institute of Aeronautics and Astronautics). Horizons is a free download using PDF format. It is typically 36 pages and 10 to 15 MB per issue. Circulation is about 400 downloads per issue, but in 2007 one issue had more than 30,000 downloads (cover story: The DIRECT Approach). A year or two earlier, one issue had over 40,000 downloads (cover story: Open Source and Free Software). Deadline for inputs for this July / August 2012 issue: August 10, 2012. This issue will be online and published by August 31, 2012. The web site will be www.aiaa-houston.org until June 30, 2012, then we are

(Continued on page 9)

REACTION ENGINES LIMITED
Space Propulsion Systems

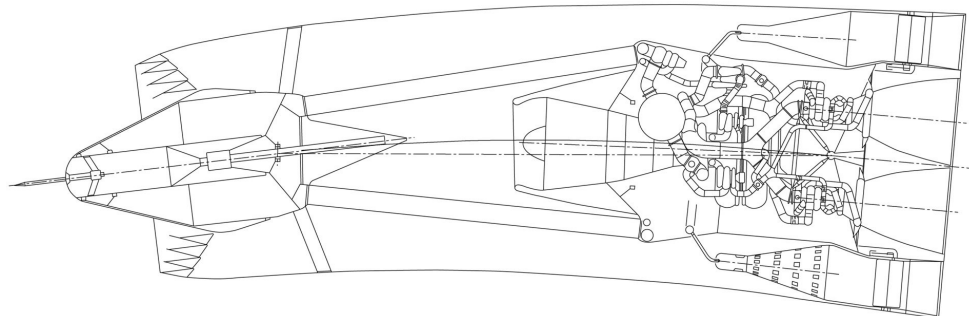

Sabre Engine Nacelle Cross Section

Skylon

(Continued from page 8)

changing everything and using www.aiaahouston.org. The following paragraphs repeat this paragraph.

About 500 words per page for about five pages, and seven pages are shown here in a planned 36-page issue of Horizons, the bimonthly newsletter of AIAA Houston Section (The American Institute of Aeronautics and Astronautics). Horizons is a free download using PDF format. It is typically 36 pages and 10 to 15 MB per issue. Circulation is about 400 downloads per issue, but in 2007 one issue had more than 30,000 downloads (cover story: The DIRECT Approach). A year or two earlier, one issue had over 40,000 downloads (cover story: Open Source and Free Software). Deadline for inputs for this July / August 2012 issue: August 10, 2012. This issue will be online and publicized by August 31, 2012. The web site will be

www.aiaa-houston.org until June 30, 2012, then we are changing everything and using www.aiaahouston.org. The following paragraphs repeat this paragraph.

About 500 words per page for about five pages, and seven pages are shown here in a planned 36-page issue of Horizons, the bimonthly newsletter of AIAA Houston Section (The American Institute of Aeronautics and Astronautics). Horizons is a free download using PDF format. It is typically 36 pages and 10 to 15 MB per issue. Circulation is about 400 downloads per issue, but in 2007 one issue had more than 30,000 downloads (cover story: The DIRECT Approach). A year or two earlier, one issue had over 40,000 downloads (cover story: Open Source and Free Software). Deadline for inputs for this July / August 2012 issue: August 10, 2012. This issue will be online and publicized by August 31, 2012.

The web site will be www.aiaa-houston.org until June 30, 2012, then we are changing everything and using www.aiaahouston.org. The following paragraphs repeat this paragraph.

About 500 words per page for about five pages, and seven pages are shown here in a planned 36-page issue of Horizons, the bimonthly newsletter of AIAA Houston Section (The American Institute of Aeronautics and Astronautics). Horizons is a free download using PDF format. It is typically 36 pages and 10 to 15 MB per issue. Circulation is about 400 downloads per issue, but in 2007 one issue had more than 30,000 downloads (cover story: The DIRECT Approach). A year or two earlier, one issue had over 40,000 downloads (cover story: Open Source and Free Software). Deadline for inputs for this July / August 2012 issue: August 10, 2012. This

(Continued on page 10)

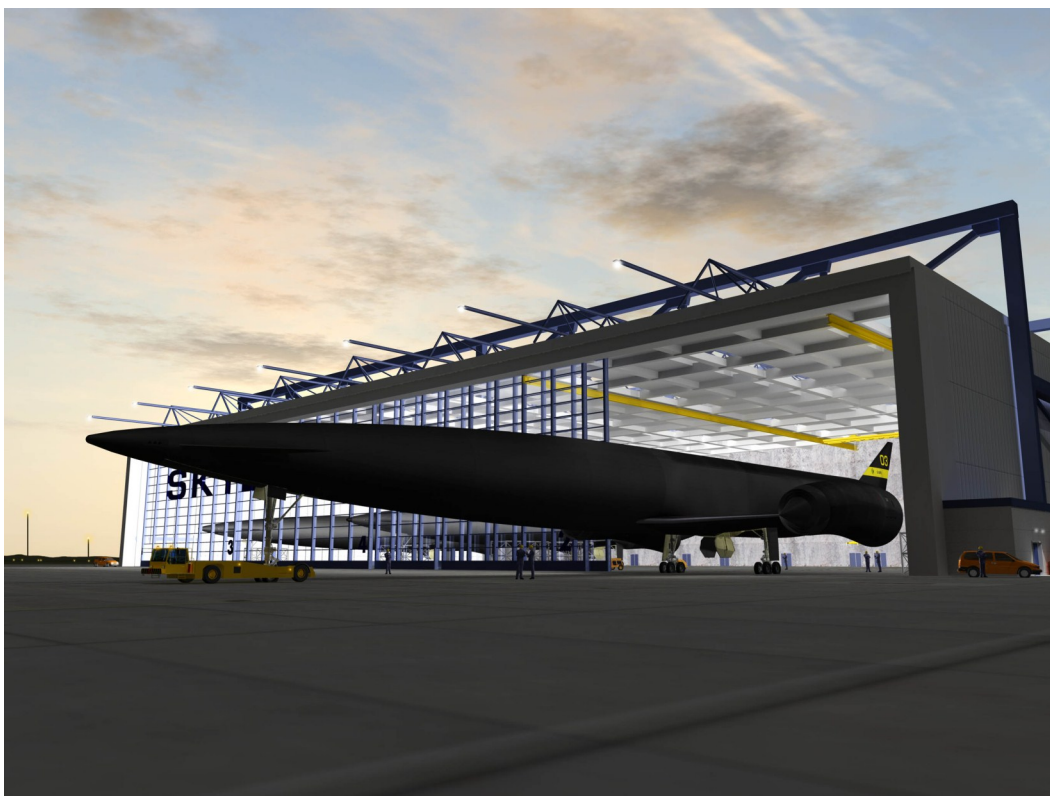

Skyron

(Continued from page 9)
 issue will be online and published by August 31, 2012. The web site will be www.aiaa-houston.org until June 30, 2012, then we are changing everything and using www.aiaahouston.org. The following paragraphs repeat this paragraph.

About 500 words per page for about five pages, and seven pages are shown here in a planned 36-page issue of Horizons, the bimonthly newsletter of AIAA Houston Section (The American Institute of Aeronautics and Astronautics). Horizons is a free download using PDF format. It is typically 36 pages and 10 to 15 MB per issue. Circulation is about 400 downloads per issue, but in 2007 one issue had more than 30,000 downloads (cover story: The DIRECT Approach). A year or two earlier, one issue had over 40,000 downloads (cover story: Open Source and Free Software). Deadline for inputs for this July / August 2012 issue: August 10, 2012. This issue will be online and published by August 31, 2012. The web site will be

www.aiaa-houston.org until June 30, 2012, then we are changing everything and using www.aiaahouston.org. The following paragraphs repeat this paragraph.

About 500 words per page for about five pages, and seven pages are shown here in a planned 36-page issue of Horizons, the bimonthly newsletter of AIAA Houston Section (The American Institute of Aeronautics and Astronautics). Horizons is a free download using PDF format. It is typically 36 pages and 10 to 15 MB per issue. Circulation is about 400 downloads per issue, but in 2007 one issue had more than 30,000 downloads (cover story: The DIRECT Approach). A year or two earlier, one issue had over 40,000 downloads (cover story: Open Source and Free Software). Deadline for inputs for this July / August 2012 issue: August 10, 2012. This issue will be online and published by August 31, 2012. The web site will be www.aiaa-houston.org until June 30, 2012, then we are changing everything and using www.aiaahouston.org.

The following paragraphs repeat this paragraph.

About 500 words per page for about five pages, and seven pages are shown here in a planned 36-page issue of Horizons, the bimonthly newsletter of AIAA Houston Section (The American Institute of Aeronautics and Astronautics). Horizons is a free download using PDF format. It is typically 36 pages and 10 to 15 MB per issue. Circulation is about 400 downloads per issue, but in 2007 one issue had more than 30,000 downloads (cover story: The DIRECT Approach). A year or two earlier, one issue had over 40,000 downloads (cover story: Open Source and Free Software). Deadline for inputs for this July / August 2012 issue: August 10, 2012. This issue will be online and published by August 31, 2012. The web site will be www.aiaa-houston.org until June 30, 2012, then we are changing everything and using www.aiaahouston.org. The following paragraphs repeat this paragraph.

(Continued on page 11)

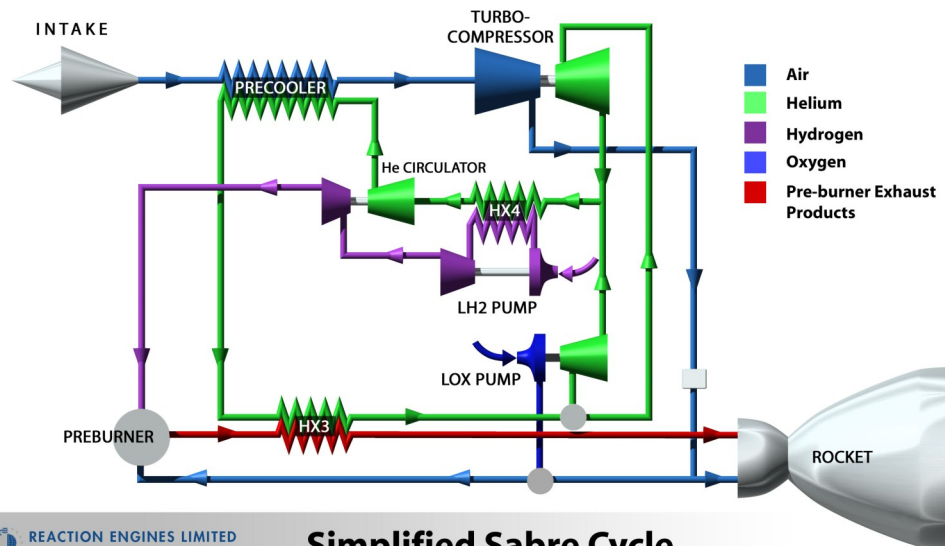

REACTION ENGINES LIMITED
 Space Propulsion Systems

Simplified Sabre Cycle

Skylon

(Continued from page 10)

About 500 words per page for about five pages, and seven pages are shown here in a planned 36-page issue of Horizons, the bimonthly newsletter.

issue will be online and published by August 31, 2012.

The web site will be www.aiaa-houston.org until June 30, 2012, then we are changing everything and us-

issue had more than 30,000 downloads (cover story: The DIRECT Approach). A year or two earlier, one issue had over 40,000 downloads (cover story: Open Source and Free



ter of AIAA Houston Section (The American Institute of Aeronautics and Astronautics). Horizons is a free download using PDF format. It is typically 36 pages and 10 to 15 MB per issue. Circulation is about 400 downloads per issue, but in 2007 one issue had more than 30,000 downloads (cover story: The DIRECT Approach). A year or two earlier, one issue had over 40,000 downloads (cover story: Open Source and Free Software). Deadline for inputs for this July / August 2012 issue: August 10, 2012. This

ing www.aiaahouston.org. The following paragraphs repeat this paragraph.

About 500 words per page for about five pages, and seven pages are shown here in a planned 36-page issue of Horizons, the bimonthly newsletter of AIAA Houston Section (The American Institute of Aeronautics and Astronautics). Horizons is a free download using PDF format. It is typically 36 pages and 10 to 15 MB per issue. Circulation is about 400 downloads per issue, but in 2007 one

Software). Deadline for inputs for this July / August 2012 issue: August 10, 2012. This issue will be online and published by August 31, 2012. The web site will be www.aiaa-houston.org until June 30, 2012, then we are changing everything and using www.aiaahouston.org. The following paragraphs repeat this paragraph.



REACTION ENGINES LTD
Space Propulsion Systems

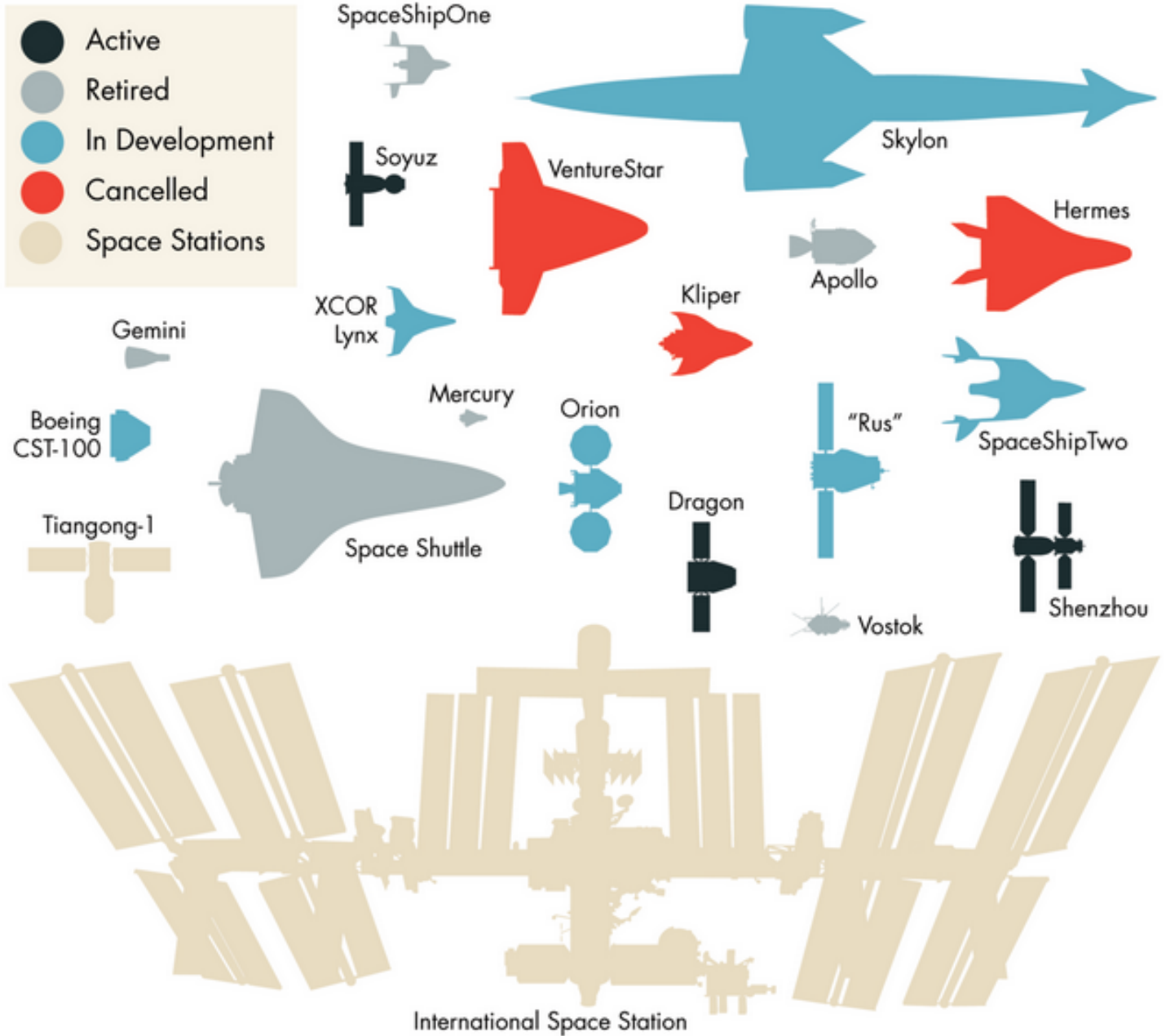

AIAA Mission & Vision Statement

The shaping, dynamic force in aerospace - THE forum for innovation, excellence and global leadership. AIAA advances the state of aerospace science, engineering, and technological leadership. Core missions include communications and advocacy, products and programs, membership value, and market and workforce development.

The World's Forum for Aerospace Leadership

Become a member of AIAA

Are you interested in becoming a member of AIAA, or renewing your membership? You can fill out your membership application online at the AIAA national web site: www.aiaa.org. Select the AIAA membership option.