

Horizons

Volume 38, Issue 1

AIAA Houston Section www.aiaahouston.org
The American Institute of Aeronautics and Astronautics

July / August 2012

Everything Ellington



RPA Mission Execution

Ellington Field Joint Reserve Base





AIAA HOUSTON
American Institute of Aeronautics and Astronautics

Horizons is a bimonthly publication of the Houston Section of the American Institute of Aeronautics and Astronautics.

Douglas Yazell
Editor

Past Editors: Dr. Steven E. Everett
Editing team: Don Kulba, Ellen Gillespie, Robert Beremand, Alan Simon, Dr. Steven Everett, Shen Ge
Regular contributors: Dr. Steven Everett, Don Kulba, Philippe Mairet, Alan Simon, Scott Lowther
Contributors this issue: Dr. Jon B. Ollansen, Sean Carter, Raphael Munoz, Michael Frostad

**AIAA Houston Section
Executive Council**

Sean Carter
Chair

Daniel Nobles
Chair-Elect

Irene Chan
Secretary

Sarah Shull
Past Chair

John Kostrzewski
Treasurer

Julie Read
Vice-Chair, Operations

Alan Sisson
Dr. Satya Pilla
Vice-Chair, Technical

Operations

Dr. Gary Turner
Shen Ge
Melissa Gordon
Lisa Voiles
Rafael Munoz
Svetlana Hanson
Michael Frostad
Dr. Benjamin Longmier
Matthew Easterly
Douglas Yazell
Gary Cowan
Joel Henry

Technical

Dr. Albert A. Jackson IV
Bebe Kelly-Serrato
Dr. Zafar Taqvi
Bill Atwell
Sheikh Ahsan
William West
Paul Nielson
Dr. Steven E. Everett
Gary Brown
Dr. Kamlesh Lulla
Ludmila Dmitriev-Odier

Councilors

Ellen Gillespie
Brian Banker
Matt Johnson
Clay Stangle
Melissa Kronenberger
Sarah Barr
Donald Barker
Shirley Brandt
Holly Feldman
Gabe Garrett

www.aiaahouston.org

July / August 2012



TABLE OF CONTENTS

From the Chair 3
From the Editor 4
Cover Story: 5

The 1940 Air Terminal Museum at Hobby Airport 13
50th Anniversary audio files

Ellington Field, Airport, Spaceport & The Lone Star Flight Museum

The Experimental Aircraft Association (EAA) Chapter 12 (Houston)
(APR by Scott Lowther)

AIAA Conference Papers by AIAA Houston Section Members

Current Events

Staying Informed

Calendar

Cranium Cruncher by Dr. Steven E. Everett

Section News

The Back Cover: 36

Horizons and AIAA Houston Section Web Site
AIAA National Communications Award Winner



This newsletter is created by members of AIAA Houston Section. Opinions expressed herein other than by elected Houston Section officers belong solely to the authors and do not necessarily represent the position of AIAA or the Houston Section. Unless explicitly stated, in no way are the comments of individual contributors to Horizons to be construed as necessarily the opinion or position of AIAA, NASA, its contractors, or any other organization. All articles in Horizons, unless otherwise noted, are the property of the individual contributors. Reproduction/republishing in any form except limited excerpts with attribution to the source, will require the express approval of the individual authors. Please address all newsletter correspondence to editor-in-chief[at]aiaa-houston.org.

Cover:

Kicking Off Our 2012-2013 Year

DANIEL NOBLES, CHAIR

From the Chair

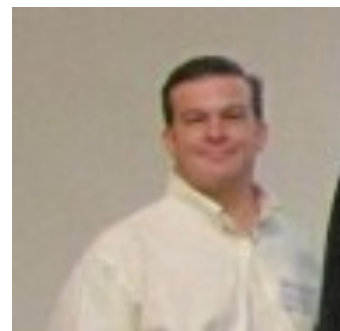

From the Editor

Skylon & New Section Logos

DOUGLAS YAZELL, EDITOR

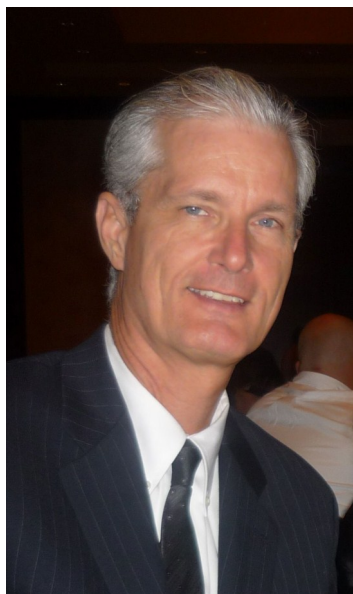

The logo below for AIAA Houston Section is new, thanks to Webmaster Irene Chan. She took some ideas from Alan Sisson, Michael Frostad and me and hit a home run with two designs.

Her second logo design is shown on the back cover. We need letterheads using these logos, and we need these logos in various colors and resolutions, but these are great candidates for our final de-

signs. Irene kept in touch with Sara Bluestone at AIAA, as recommended in the AIAA branding & logos manual, so these two designs respect the official guidelines.



E-mail:
[editor2012\[at\]aiaahouston.org](mailto:editor2012[at]aiaahouston.org)

For a Horizons archive on a national AIAA web site click [here](#).

www.aiaahouston.org



Skylon

GEORGE W. S. ABBEY, JR.

Cover Story

About 500 words per page for about five pages, and seven pages are shown here in a planned 36-page issue of Horizons, the bimonthly newsletter of AIAA Houston Section (The American Institute of Aeronautics and Astronautics). Horizons is a free download using PDF format. It is typically 36 pages and 10 to 15 MB per issue. Circulation is about 400 downloads per issue, but in 2007 one issue had more than 30,000 downloads (cover story: The DIRECT Approach). A year or two earlier, one issue had over 40,000 downloads (cover story: Open Source and Free Software). Deadline for inputs for this July / August 2012 issue: August 10, 2012. This issue will be online and publicized by August 31, 2012. The web site will be www.aiaa-houston.org until June 30, 2012, then we are changing everything and us-

ing www.aiaahouston.org. The following paragraphs repeat this paragraph.

About 500 words per page for about five pages, and seven pages are shown here in a planned 36-page issue of Horizons, the bimonthly newsletter of AIAA Houston Section (The American Institute of Aeronautics and Astronautics). Horizons is a free download using PDF format. It is typically 36 pages and 10 to 15 MB per issue. Circulation is about 400 downloads per issue, but in 2007 one issue had more than 30,000 downloads (cover story: The DIRECT Approach). A year or two earlier, one issue had over 40,000 downloads (cover story: Open Source and Free Software). Deadline for inputs for this July / August 2012 issue: August 10, 2012. This issue will be

online and publicized by August 31, 2012. The web site will be www.aiaa-houston.org until June 30, 2012, then we are changing everything and using www.aiaahouston.org. The following paragraphs repeat this paragraph.

About 500 words per page for about five pages, and seven pages are shown here in a planned 36-page issue of Horizons, the bimonthly newsletter of AIAA Houston Section (The American Institute of Aeronautics and Astronautics). Horizons is a free download using PDF format. It is typically 36 pages and 10 to 15 MB per issue. Circulation is about 400 downloads per issue, but in 2007 one issue had more than 30,000 downloads (cover story: The DIRECT Approach). A year or two earlier, one issue had

(Continued on page 6)

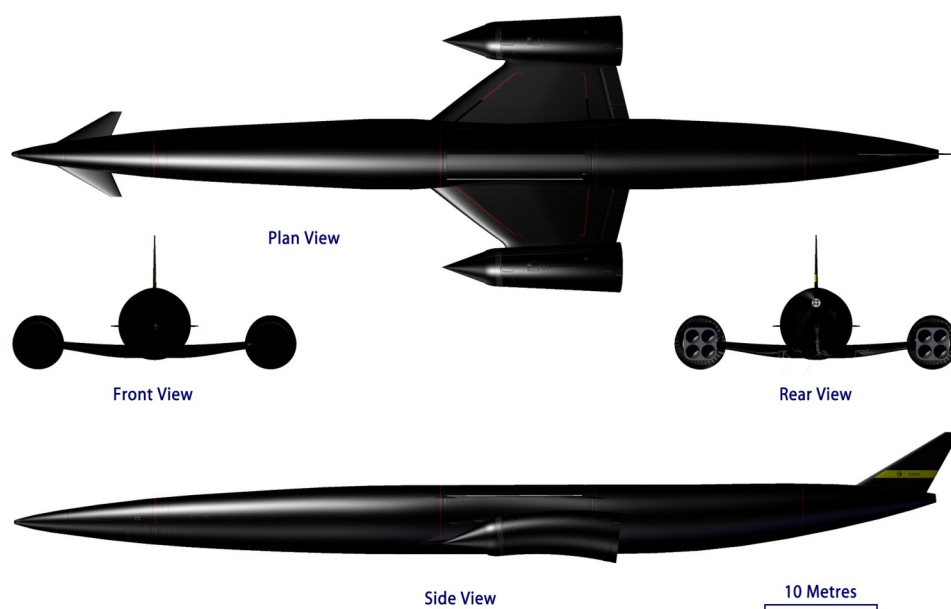

Skylon

(Continued from page 5)
 over 40,000 downloads (cover story: Open Source and Free Software). Deadline for inputs for this July / August 2012 issue: August 10, 2012. This issue will be online and published by August 31, 2012. The web site will be www.aiaa-houston.org until June 30, 2012, then we are changing everything and using www.aiaahouston.org. The following paragraphs repeat this paragraph.

About 500 words per page for about five pages, and seven pages are shown here in a planned 36-page issue of Horizons, the bimonthly newsletter of AIAA Houston Section (The American Institute of Aeronautics and Astronautics). Horizons is a free download using PDF format. It is typically 36 pages and 10 to 15 MB per issue. Circulation is about 400 downloads per issue, but in 2007 one issue had more than 30,000 downloads (cover story: The DIRECT Approach). A year or two earlier, one issue had over 40,000 downloads (cover story: Open Source and Free Software). Deadline for inputs for this July / August 2012

issue: August 10, 2012. This issue will be online and published by August 31, 2012. The web site will be www.aiaa-houston.org until June 30, 2012, then we are changing everything and using www.aiaahouston.org. The following paragraphs repeat this paragraph.

About 500 words per page for about five pages, and seven pages are shown here in a planned 36-page issue of Horizons, the bimonthly newsletter of AIAA Houston Section (The American Institute of Aeronautics and Astronautics). Horizons is a free download using PDF format. It is typically 36 pages and 10 to 15 MB per issue. Circulation is about 400 downloads per issue, but in 2007 one issue had more than 30,000 downloads (cover story: The DIRECT Approach). A year or two earlier, one issue had over 40,000 downloads (cover story: Open Source and Free Software). Deadline for inputs for this July / August 2012 issue: August 10, 2012. This issue will be online and published by August 31, 2012. The web site will be www.aiaa-houston.org until

June 30, 2012, then we are changing everything and using www.aiaahouston.org. The following paragraphs repeat this paragraph.

About 500 words per page for about five pages, and seven pages are shown here in a planned 36-page issue of Horizons, the bimonthly newsletter of AIAA Houston Section (The American Institute of Aeronautics and Astronautics). Horizons is a free download using PDF format. It is typically 36 pages and 10 to 15 MB per issue. Circulation is about 400 downloads per issue, but in 2007 one issue had more than 30,000 downloads (cover story: The DIRECT Approach). A year or two earlier, one issue had over 40,000 downloads (cover story: Open Source and Free Software). Deadline for inputs for this July / August 2012 issue: August 10, 2012. This issue will be online and published by August 31, 2012. The web site will be www.aiaa-houston.org until June 30, 2012, then we are changing everything and using www.aiaahouston.org.

(Continued on page 7)

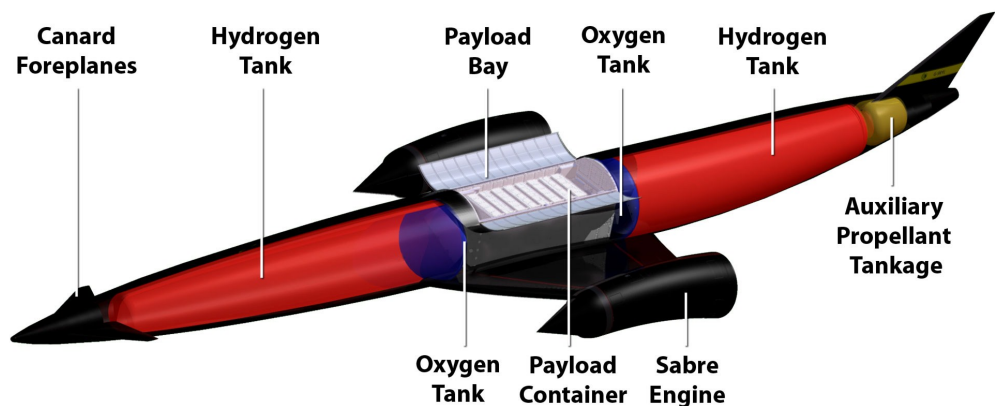

Skylon

(Continued from page 6)

The following paragraphs repeat this paragraph.

About 500 words per page for about five pages, and seven pages are shown here in a planned 36-page issue of Horizons, the bimonthly newsletter of AIAA Houston Section (The American Institute of Aeronautics and Astronautics). Horizons is a free download using PDF format. It is typically 36 pages and 10 to 15 MB per issue. Circulation is about 400 downloads per issue, but in 2007 one issue had more than 30,000 downloads (cover story: The DIRECT Approach). A year or two earlier, one issue had over 40,000 downloads (cover story: Open Source and Free Software). Deadline for inputs for this July / August 2012 issue: August 10, 2012. This issue will be online and publicized by August 31, 2012. The web site will be

www.aiaa-houston.org until June 30, 2012, then we are changing everything and using www.aiaahouston.org. The following paragraphs repeat this paragraph.

About 500 words per page for about five pages, and seven pages are shown here in a planned 36-page issue of Horizons, the bimonthly newsletter of AIAA Houston Section (The American Institute of Aeronautics and Astronautics). Horizons is a free download using PDF format. It is typically 36 pages and 10 to 15 MB per issue. Circulation is about 400 downloads per issue, but in 2007 one issue had more than 30,000 downloads (cover story: The DIRECT Approach). A year or two earlier, one issue had over 40,000 downloads (cover story: Open Source and Free Software). Deadline for inputs for this July / August 2012 issue: August 10, 2012. This

issue will be online and publicized by August 31, 2012.

The web site will be www.aiaa-houston.org until June 30, 2012, then we are changing everything and using www.aiaahouston.org. The following paragraphs repeat this paragraph.

About 500 words per page for about five pages, and seven pages are shown here in a planned 36-page issue of Horizons, the bimonthly newsletter of AIAA Houston Section (The American Institute of Aeronautics and Astronautics). Horizons is a free download using PDF format. It is typically 36 pages and 10 to 15 MB per issue. Circulation is about 400 downloads per issue, but in 2007 one issue had more than 30,000 downloads (cover story: The DIRECT Approach). A year or two earlier, one issue had over 40,000 downloads (cover story: Open Source and Free

(Continued on page 8)

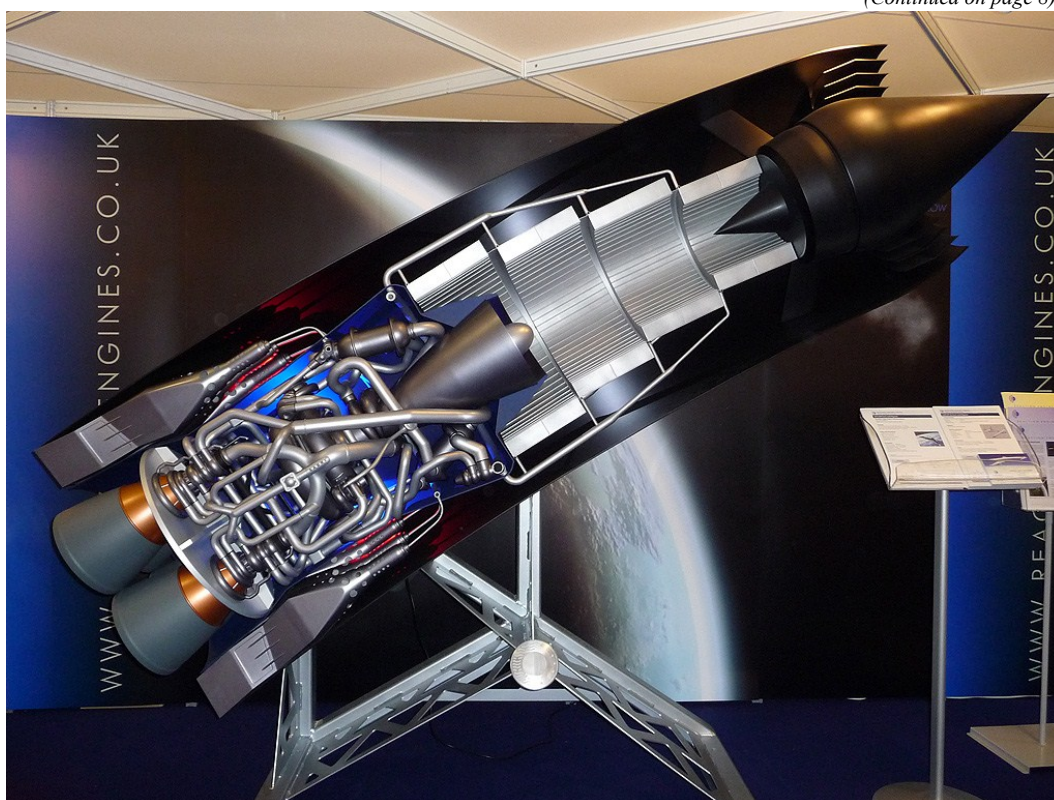

Skylon

(Continued from page 7)
Software). Deadline for inputs for this July / August 2012 issue: August 10, 2012. This issue will be online and published by August 31, 2012. The web site will be www.aiaa-houston.org until June 30, 2012, then we are changing everything and using www.aiaahouston.org. The following paragraphs repeat this paragraph.

About 500 words per page for about five pages, and seven pages are shown here in a planned 36-page issue of Horizons, the bimonthly newsletter of AIAA Houston Section (The American Institute of Aeronautics and Astronautics). Horizons is a free download using PDF format. It is typically 36 pages and 10 to 15 MB per issue. Circulation is about 400 downloads per issue, but in 2007 one issue had more than 30,000 downloads (cover story: The DIRECT Approach). A year or two earlier, one issue had over 40,000 downloads (cover story: Open Source and Free Software). Deadline for inputs for this July / August 2012

issue: August 10, 2012. This issue will be online and published by August 31, 2012. The web site will be www.aiaa-houston.org until June 30, 2012, then we are changing everything and using www.aiaahouston.org. The following paragraphs repeat this paragraph.

About 500 words per page for about five pages, and seven pages are shown here in a planned 36-page issue of Horizons, the bimonthly newsletter of AIAA Houston Section (The American Institute of Aeronautics and Astronautics). Horizons is a free download using PDF format. It is typically 36 pages and 10 to 15 MB per issue. Circulation is about 400 downloads per issue, but in 2007 one issue had more than 30,000 downloads (cover story: The DIRECT Approach). A year or two earlier, one issue had over 40,000 downloads (cover story: Open Source and Free Software). Deadline for inputs for this July / August 2012 issue: August 10, 2012. This issue will be online and published by August 31, 2012.

The web site will be www.aiaa-houston.org until June 30, 2012, then we are changing everything and using www.aiaahouston.org. The following paragraphs repeat this paragraph.

About 500 words per page for about five pages, and seven pages are shown here in a planned 36-page issue of Horizons, the bimonthly newsletter of AIAA Houston Section (The American Institute of Aeronautics and Astronautics). Horizons is a free download using PDF format. It is typically 36 pages and 10 to 15 MB per issue. Circulation is about 400 downloads per issue, but in 2007 one issue had more than 30,000 downloads (cover story: The DIRECT Approach). A year or two earlier, one issue had over 40,000 downloads (cover story: Open Source and Free Software). Deadline for inputs for this July / August 2012 issue: August 10, 2012. This issue will be online and published by August 31, 2012. The web site will be www.aiaa-houston.org until June 30, 2012, then we are

(Continued on page 9)

REACTION ENGINES LIMITED
Space Propulsion Systems

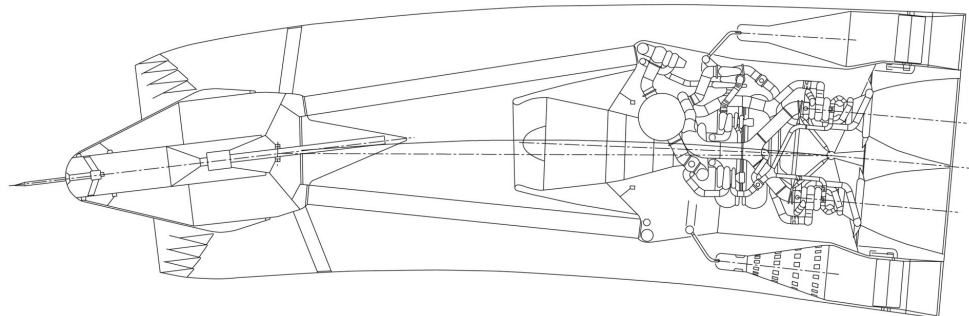

Sabre Engine Nacelle Cross Section

Skylon

(Continued from page 8)
changing everything and using www.aiaahouston.org. The following paragraphs repeat this paragraph.

About 500 words per page for about five pages, and seven pages are shown here in a planned 36-page issue of Horizons, the bimonthly newsletter of AIAA Houston Section (The American Institute of Aeronautics and Astronautics). Horizons is a free download using PDF format. It is typically 36 pages and 10 to 15 MB per issue. Circulation is about 400 downloads per issue, but in 2007 one issue had more than 30,000 downloads (cover story: The DIRECT Approach). A year or two earlier, one issue had over 40,000 downloads (cover story: Open Source and Free Software). Deadline for inputs for this July / August 2012 issue: August 10, 2012. This issue will be online and publicized by August 31, 2012. The web site will be

www.aiaa-houston.org until June 30, 2012, then we are changing everything and using www.aiaahouston.org. The following paragraphs repeat this paragraph.

About 500 words per page for about five pages, and seven pages are shown here in a planned 36-page issue of Horizons, the bimonthly newsletter of AIAA Houston Section (The American Institute of Aeronautics and Astronautics). Horizons is a free download using PDF format. It is typically 36 pages and 10 to 15 MB per issue. Circulation is about 400 downloads per issue, but in 2007 one issue had more than 30,000 downloads (cover story: The DIRECT Approach). A year or two earlier, one issue had over 40,000 downloads (cover story: Open Source and Free Software). Deadline for inputs for this July / August 2012 issue: August 10, 2012. This issue will be online and publicized by August 31, 2012.

The web site will be www.aiaa-houston.org until June 30, 2012, then we are changing everything and using www.aiaahouston.org. The following paragraphs repeat this paragraph.

About 500 words per page for about five pages, and seven pages are shown here in a planned 36-page issue of Horizons, the bimonthly newsletter of AIAA Houston Section (The American Institute of Aeronautics and Astronautics). Horizons is a free download using PDF format. It is typically 36 pages and 10 to 15 MB per issue. Circulation is about 400 downloads per issue, but in 2007 one issue had more than 30,000 downloads (cover story: The DIRECT Approach). A year or two earlier, one issue had over 40,000 downloads (cover story: Open Source and Free Software). Deadline for inputs for this July / August 2012 issue: August 10, 2012. This

(Continued on page 10)



Skyron

(Continued from page 9)
 issue will be online and published by August 31, 2012. The web site will be www.aiaa-houston.org until June 30, 2012, then we are changing everything and using www.aiaahouston.org. The following paragraphs repeat this paragraph.

About 500 words per page for about five pages, and seven pages are shown here in a planned 36-page issue of Horizons, the bimonthly newsletter of AIAA Houston Section (The American Institute of Aeronautics and Astronautics). Horizons is a free download using PDF format. It is typically 36 pages and 10 to 15 MB per issue. Circulation is about 400 downloads per issue, but in 2007 one issue had more than 30,000 downloads (cover story: The DIRECT Approach). A year or two earlier, one issue had over 40,000 downloads (cover story: Open Source and Free Software). Deadline for inputs for this July / August 2012 issue: August 10, 2012. This issue will be online and published by August 31, 2012. The web site will be

www.aiaa-houston.org until June 30, 2012, then we are changing everything and using www.aiaahouston.org. The following paragraphs repeat this paragraph.

About 500 words per page for about five pages, and seven pages are shown here in a planned 36-page issue of Horizons, the bimonthly newsletter of AIAA Houston Section (The American Institute of Aeronautics and Astronautics). Horizons is a free download using PDF format. It is typically 36 pages and 10 to 15 MB per issue. Circulation is about 400 downloads per issue, but in 2007 one issue had more than 30,000 downloads (cover story: The DIRECT Approach). A year or two earlier, one issue had over 40,000 downloads (cover story: Open Source and Free Software). Deadline for inputs for this July / August 2012 issue: August 10, 2012. This issue will be online and published by August 31, 2012. The web site will be www.aiaa-houston.org until June 30, 2012, then we are changing everything and using www.aiaahouston.org.

The following paragraphs repeat this paragraph.

About 500 words per page for about five pages, and seven pages are shown here in a planned 36-page issue of Horizons, the bimonthly newsletter of AIAA Houston Section (The American Institute of Aeronautics and Astronautics). Horizons is a free download using PDF format. It is typically 36 pages and 10 to 15 MB per issue. Circulation is about 400 downloads per issue, but in 2007 one issue had more than 30,000 downloads (cover story: The DIRECT Approach). A year or two earlier, one issue had over 40,000 downloads (cover story: Open Source and Free Software). Deadline for inputs for this July / August 2012 issue: August 10, 2012. This issue will be online and published by August 31, 2012. The web site will be www.aiaa-houston.org until June 30, 2012, then we are changing everything and using www.aiaahouston.org. The following paragraphs repeat this paragraph.

(Continued on page 11)

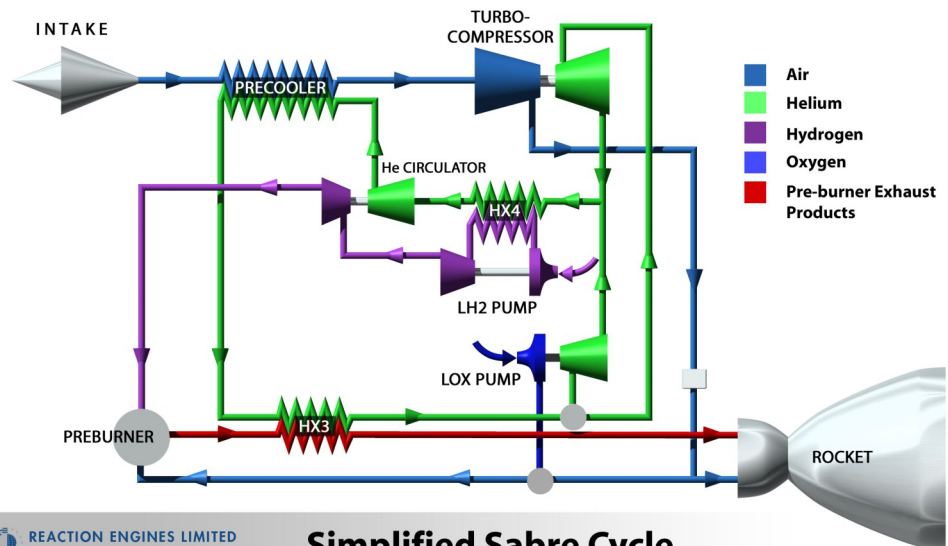

REACTION ENGINES LIMITED
 Space Propulsion Systems

Simplified Sabre Cycle

Skylon

(Continued from page 10)

About 500 words per page for about five pages, and seven pages are shown here in a planned 36-page issue of Horizons, the bimonthly newsletter.

issue will be online and published by August 31, 2012.

The web site will be www.aiaa-houston.org until June 30, 2012, then we are changing everything and us-

issue had more than 30,000 downloads (cover story: The DIRECT Approach). A year or two earlier, one issue had over 40,000 downloads (cover story: Open Source and Free



ter of AIAA Houston Section (The American Institute of Aeronautics and Astronautics). Horizons is a free download using PDF format. It is typically 36 pages and 10 to 15 MB per issue. Circulation is about 400 downloads per issue, but in 2007 one issue had more than 30,000 downloads (cover story: The DIRECT Approach). A year or two earlier, one issue had over 40,000 downloads (cover story: Open Source and Free Software). Deadline for inputs for this July / August 2012 issue: August 10, 2012. This

ing www.aiaahouston.org. The following paragraphs repeat this paragraph.

About 500 words per page for about five pages, and seven pages are shown here in a planned 36-page issue of Horizons, the bimonthly newsletter of AIAA Houston Section (The American Institute of Aeronautics and Astronautics). Horizons is a free download using PDF format. It is typically 36 pages and 10 to 15 MB per issue. Circulation is about 400 downloads per issue, but in 2007 one

Software). Deadline for inputs for this July / August 2012 issue: August 10, 2012. This issue will be online and published by August 31, 2012. The web site will be www.aiaa-houston.org until June 30, 2012, then we are changing everything and using www.aiaahouston.org. The following paragraphs repeat this paragraph.



REACTION ENGINES LTD
Space Propulsion Systems

Keyword

Title
AUTHOR

1940 Air Terminal Museum at Hobby Airport An AIAA Historic Aerospace Site

DOUGLAS YAZELL, EDITOR

Museum

A bimonthly column about The 1940 Air Terminal Museum, a 2008 addition to the list of AIAA Historic Aerospace Sites. The museum is restored and operated by the non-profit Houston Aeronautical Heritage Society.

1940 Air Terminal Museum
8325 Travelair Street
Houston, Texas 77061
(713) 454-1940

3AF MP

The European Space Agency Awards Two Studies to EADS Astrium

PHILIPPE MAIRET, 3AF MP AND DOUGLAS YAZELL, EDITOR

Our French sister section is 3AF MP, l'Association Aeronautique et Astronautique de France, Midi-Pyrenees chapter, www.3af-mp.fr. More information was on our web page at www.aiaa-houston.org, and as of July 1, 2012, that web site is moving to www.aiaahouston.org. Click on technical committees, then International Space Activities Committee (ISAC). The ISAC is chaired by Ludmila Dmitriev-Odier. See the Section News page of this issue for the 3AF MP organization chart.

The European Aeronautic Defense and Space Company (EADS) Astrium has been selected by the European Space Agency (ESA) to conduct two studies, both to be complete, if possible, before the meeting of the ESA member states at the next Ministerial Council in November 2012.

(Continued on page 15)

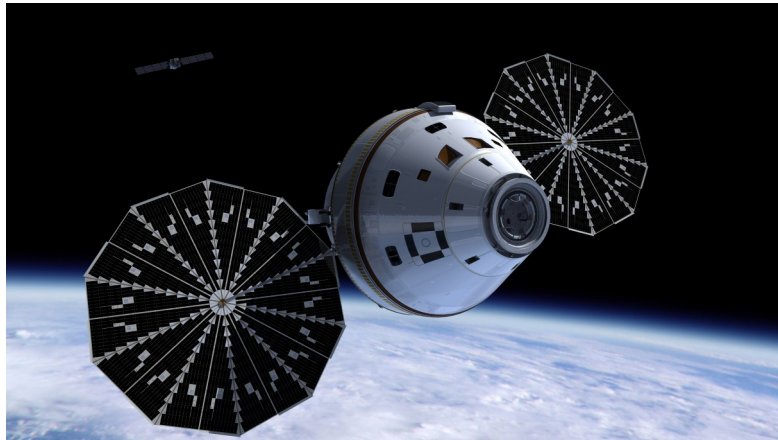

Left: Orion MPCV and its service module with solar panels attached to the service module. Image credit: NASA Glenn Research Center (GRC).

ISS030-E-175090 (28 March 2012) --- European Space Agency's Edoardo Amaldi Automated Transfer Vehicle-3 (ATV-3) approaches the International Space Station. The cargo spacecraft docked to the space station at 6:31 p.m. (EDT) on March 28, 2012, delivering 220 pounds of oxygen, 628 pounds of water, 4.5 tons of propellant, and nearly 2.5 tons of dry cargo, including experiment hardware, spare parts, food and clothing. Image credit: NASA.



The AIAA Houston Section logo is a preliminary version in work as of June 29, 2012.



Midi-Pyrénées



3AF MP

(Continued from page 14)

The first study will, "... explore different service module solutions for the Orion Multi-Purpose Crew Vehicle (MPCV) spacecraft of The United States of America, a vehicle dedicated to human spaceflight exploration. These solutions will be based on technologies developed for the service module of [ESA's] Automated Transfer Vehicle (ATV)."

The second study, "...will identify and define the concept of [a new] autonomous spacecraft with an intrinsic versatility, also based on the know-how and technolo-

gies of the ATV." The adjustments made to this vehicle will ensure it many future missions, mainly in the areas

of, "transport missions to infrastructure in Low Earth Orbit (LEO)", "in-orbit service missions targeting a spacecraft or debris," and "supply missions for the benefit of autonomous platforms / habitats."

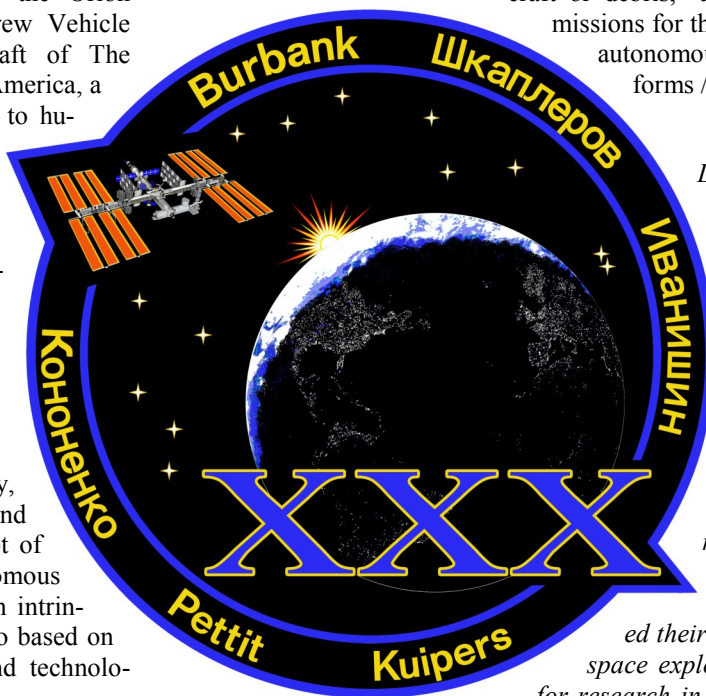

Left: ISS030-S-001 (April 2011) --- The International Space Station (ISS) program is completing the transition from assembly to full utilization as humankind celebrates the golden anniversary of human space exploration. In recognition of these milestones and especially of the contribution of those whose dedication and ingenuity make spaceflight possible, a fully assembled ISS is depicted rising above a sunlit Earth limb. Eastward of the sunlit limb, the distinctive portrayal of Earth's surface illuminated by nighttime city lights is a reminder of mankind's presence on the planet, most readily apparent from space only by night, and commemorates how human beings have transcended their early bonds throughout the previous 50 years of space exploration.

The ISS, a unique space-based outpost for research in biological, physical, space and Earth sciences, in the words of the crew members, is an impressive testament to the tremendous teamwork of the engineers, scientists and technicians from 15 countries and five national space agencies. The six crew members of Expedition 30, like those who have gone before them, express that they are honored to represent their countries and the ISS team in conducting research aboard the station and adding to the body of knowledge that will enable the world's space faring countries to more safely and more productively live, work and explore outer space, paving the way for future missions beyond low Earth orbit, and inspiring young people to join in this great adventure. Image credit: NASA.



Left: JSC2011-E-120614 (20 Sept. 2011) --- European Space Agency astronaut Andre Kuipers, Expedition 30/31 flight engineer, poses for a portrait following an Expedition 30/31 preflight press conference at NASA's Johnson Space Center. Image credit: NASA.

100 Year Starship (100YSS)

www.100yss.org

100YSS 2012 Public Symposium in Houston

DOUGLAS YAZELL, EDITOR

Press release from the Dorothy Jemison Foundation for Excellence

Mae Jemison and Team Establish 100 Year Starship with Goal to Make Interstellar Space Travel Reality by 2112

Houston, TX, May 17, 2012 — **The Dorothy Jemison Foundation for Excellence** has been selected by the Defense Advanced Research Projects Agency (DARPA) to receive seed money to form **100 Year Starship (100YSS)**, an independent, non-government, long-term initiative which will ensure the capabilities for human interstellar flight exist as soon as possible, and definitely within the next 100 years. The winning 100YSS proposal, “An Inclusive, Audacious Journey Transforms Life Here on Earth and Beyond,” was created by the Dorothy Jemison Foundation for Excellence with team members **Icarus Interstellar** and **The Foundation for Enterprise**

Development.

Former NASA astronaut Mae Jemison will lead the global multi-partner organization. Dr. Jemison, the world’s first woman of color to travel in space (1992’s Space Shuttle Endeavour), brings to her leadership role her vast experience as an engineer, physician, professor, former Peace Corps medical officer and entrepreneur. Known for achieving the improbable, Dr. Jemison also brings a spirit of audacity, innovation and inclusion to 100YSS.

“Yes, it can be done. Our current technology arc is sufficient,” says Dr. Jemison. “100 Year Starship is about building the tools we need to travel

to another star system in the next hundred years. We’re embarking on a journey across time and space. If my language is dramatic, it is because this project is monumental. This is a global aspiration. And each step of the way, its progress will benefit life on Earth. Our team is both invigorated and sobered by the confidence DARPA has in us to start an independent, private initiative to help make interstellar travel a reality.”

100 Year Starship will bring in experts from myriad fields to help achieve its goal - utilizing not only scientists, engineers, doctors, technologists, researchers, sociologists and computer experts, but

(Continued on page 17)

Right: An exoplanet image created by an artist. Image source: Wikipedia. Image credit: Get it from there.



(Continued from page 16)

also architects, writers, artists, entertainers, and leaders in government, business, economics, ethics and public policy. 100YSS will also collaborate with existing space exploration and advocacy efforts from both private enterprise and the government.

In its first year, 100YSS will seek investors, establish membership opportunities, encourage public participation in research projects, and develop the visions for interstellar exploration. A **100 Year Starship Public Symposium** will be held in Houston September 13-16, 2012, inaugurating what will be an annual event open to scientific papers, engineering challenges, philosophical and socio-cultural considerations, economic incentives, application of space techniques to improve life on Earth, imaginative exploration of the stumbling blocks and opportunities to the stars, and broad public involvement.

The 100 Year Starship also will include a scientific institute, **The Way**, whose major emphasis will be speculative, long-term science and technology.

Alongside the Dorothy Jemison Foundation for Excellence, a non-profit organization that promotes science, technology, engineering and mathematics (STEM) awareness and achievement, the principal 100 Year Starship team members are: **Icarus Interstellar**, a non-profit research and development organization dedicated to the research that will enable interstellar flight, and **The Foundation for Enterprise Devel-**

100YSS™ 2012 Public Symposium

Transition to Transformation...The Journey Begins
September 13 - 16, 2012 | Houston, TX

100 Year Starship (100YSS)

Registration Costs

Registration Type	Cost	Student*
Early Registration (Ends July 7th)	\$200	\$100
Regular Registration (Ends August 30th)	\$250	\$150
Late/Onsite Registration	\$300	\$175
Press Registration	See form below	

* Students must present a valid school ID at registration and have a school email address to obtain this rate.

opment, centered on governance, innovation, entrepreneurship, technology and R & D based organizational planning, management and strategic planning. **The SETI Institute**, a private non-profit organization dedicated to astronomy, life sciences, education and public outreach, will hold a permanent seat on the 100YSS Advisory Council.

To sign up for e-mail alerts from 100 Year Starship or learn more about the 100YSS Public Symposium, visit www.100YSS.org. Follow 100 Year Starship on Twitter (@100YSS). Contact 100 Year Starship at info@100YSS.org.

2012



2011 100YSS Public Symposium
Hyatt Regency Houston
1200 Louisiana Street
Houston, TX 77002
US

Phone: 402-592-6464 / 888-421-1442

www.100yss.org

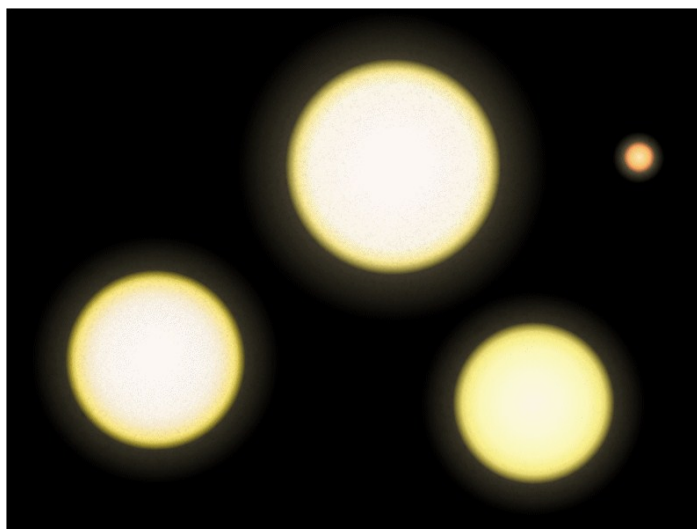

Left: Our Sun (left) and the three stars in the Proxima Centauri (?) system of stars, the nearest three stars to our solar system, at about four light years away. Obtain the caption from Wikipedia. Image source: Wikipedia. Image credit: Easy to obtain for this box.

Keyword

Title
AUTHOR

The Experimental Aircraft Association (EAA) Chapter 12 (Houston)



Mission

The EAA's Chapter 12, located at Ellington Field in Houston, Texas, is an organization that promotes all forms of recreational aviation. The organization includes interest in homebuilt, experimental, antique and classic, warbirds, aerobatic aircraft, ultra lights, helicopters and commercially manufactured aircraft and the associated technologies. This organization brings people together with an interest in recreational aviation, facilitating social interaction and information sharing between aviation enthusiasts. Many of the services that EAA offers provide valuable

support resources for those that wish develop and improve various skills related to aircraft construction and restoration, piloting, aviation safety, and aviation education.

Every individual and organization with an interest in aviation and aviation technology is encouraged to participate (EAA membership is not required, but encouraged). Meetings are generally from 6:30 PM to 9 PM at Ellington Field in Houston Texas. We welcome everyone. Come as you are and bring a guest; we are an all aviation friendly organization!

Ideas for a meeting? Contact Richard at [rtsessions\[at\]earthlink.net](mailto:rtsessions[at]earthlink.net), Chapter 12 web site: www.eaa12.org. Another email contact: [eaachapt12\[at\]gmail.com](mailto:eaachapt12[at]gmail.com). As of April 13, 2012, EAA Chapter 12 is meeting on the first Tuesday of month, based on the calendar on the web site.

Experimental Aircraft Association (EAA) web site: www.eaa.org

Scheduled/Preliminary Chapter 12 Event/Meeting Ideas and Recurring Events:

- 1st Saturday of each month – La Grange TX BBQ Fly-In, Fayette Regional (3T5)
- 1st Saturdays – Waco/Macgregor TX (KPWG), Far East Side of Field, Chap 59, Pancake Breakfast with all the goodies 8-10 AM, Dale Breedlove, [jdbvmt\[at\]netscape.com](mailto:jdbvmt[at]netscape.com)
- 2nd Saturdays – Conroe TX Chapter 302 10 AM Lone Star Builder's Ctr, Lone Star Executive
- 2nd Saturdays – Lufkin TX Fajita Fly-In (LFK)
- 2nd Saturdays – New Braunfels TX Pancake Fly-In
- 3rd Saturdays – Wings & Wheels, 1941 Air Terminal Museum, Hobby Airport, Houston TX
- 3rd Saturdays – Jasper TX BBQ Lunch Fly-In (JAS)
- 3rd Saturdays – Tyler TX Breakfast Fly-In, 8-11, Pounds Field (TYR)
- 4th Saturdays – Denton TX Tex-Mex Fly-In
- 4th Saturdays – Leesville LA Lunch Fly-In (L39)
- 4th Saturdays – Shreveport LA Lunch Fly-In (DTN)
- Last Saturdays – Denton Fly-In 11AM-2 PM (KDTO)

In our May 2011 issue we started our series "EAA/AIAA profiles in general and experimental aviation" with Lance Borden, who is rebuilding his Inland Sport airplane, an aircraft manufactured by his grandfather's 1929 - 1932 company. The second in this series was a profile of Paul F. Dye. The third profile will appear as soon as possible. This series was suggested by Richard Sessions of EAA Chapter 12.



APR
E-Publication

Title
SCOTT LOWTHER

**Aerospace Projects
Review**

Aerospace Projects Review (APR) is presented by Scott Lowther, whose unique electronic publication is described as a “journal devoted to the untold tales of aerospacecraft design.” More information may be found at the following address:

*Scott Lowther
11305 W 10400 N
Thatcher, UT 84337
scottlowther@ix.netcom.com
www.aerospaceprojectsreview.com*

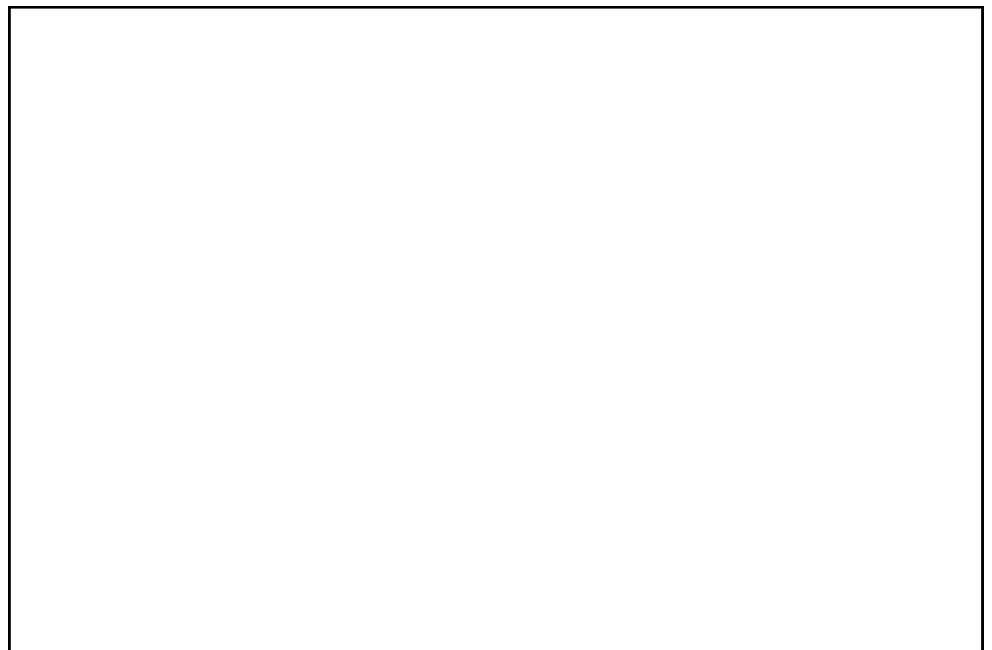

APR
E-Publication



APR
E-Publication

APR
E-Publication

Everything Ellington

Everything Ellington

MARIO DIAZ & COLONEL JACK "STITCH" DANIEL

About 500 words per page for about five pages, and seven pages are shown here in a planned 36-page issue of Horizons, the bimonthly newsletter of AIAA Houston Section (The American Institute of Aeronautics and Astronautics). Horizons is a free download using PDF format. It is typically 36 pages and 10 to 15 MB per issue. Circulation is about 400 downloads per issue, but in 2007 one issue had more than 30,000 downloads (cover story: The DIRECT Approach). A year or two earlier, one issue had over 40,000 downloads (cover story: Open Source and Free Software). Deadline for inputs for this July / August 2012 issue: August 10, 2012. This issue will be online and publicized by August 31, 2012. The web site will be www.aiaa-houston.org until June 30, 2012, then we are changing everything and using www.aiaahouston.org. The following paragraphs repeat this paragraph.

over 40,000 downloads (cover story: Open Source and Free Software). Deadline for inputs for this July / August 2012 issue: August 10, 2012. This issue will be online and publicized by August 31, 2012. The web site will be www.aiaa-houston.org until June 30, 2012, then we are changing everything and using www.aiaahouston.org. The following paragraphs repeat this paragraph.

About 500 words per page for about five pages, and seven pages are shown here in a planned 36-page issue of Horizons, the bimonthly newsletter of AIAA Houston Section (The American Institute of Aeronautics and Astronautics). Horizons is a free download using PDF format. It is typically 36 pages and 10 to 15 MB per issue. Circulation is about 400 downloads per issue, but in 2007 one issue had more than 30,000

(Continued on page 25)

Right: The first chart from the presentation by Mr. Mario Diaz. Image credit: Houston Airports.

About 500 words per page for about five pages, and seven pages are shown here in a planned 36-page issue of Horizons, the bimonthly newsletter of AIAA Houston Section (The American Institute of Aeronautics and Astronautics). Horizons is a free download using PDF format. It is typically 36 pages and 10 to 15 MB per issue. Circulation is about 400 downloads per issue, but in 2007 one issue had more than 30,000 downloads (cover story: The DIRECT Approach). A year or two earlier, one issue had



Everything Ellington

(Continued from page 24)
 downloads (cover story: The DIRECT Approach). A year or two earlier, one issue had over 40,000 downloads (cover story: Open Source and Free Software). Deadline for inputs for this July / August 2012 issue: August 10, 2012. This issue will be online and published by August 31, 2012. The web site will be www.aiaa-houston.org until June 30, 2012, then we are changing everything and using www.aiaahouston.org. The following paragraphs repeat this paragraph.

About 500 words per page for about five pages, and seven pages are shown here in a planned 36-page issue of Horizons, the bimonthly newsletter of AIAA Houston Section (The American Institute of Aeronautics and Astronautics). Horizons is a free

download using PDF format. It is typically 36 pages and 10 to 15 MB per issue. Circulation is about 400 downloads per issue, but in 2007 one issue had more than 30,000 downloads (cover story: The DIRECT Approach). A year or two earlier, one issue had over 40,000 downloads (cover story: Open Source and Free Software). Deadline for inputs for this July / August 2012 issue: August 10, 2012. This issue will be online and published by August 31, 2012. The web site will be www.aiaa-houston.org until June 30, 2012, then we are changing everything and using www.aiaahouston.org. The following paragraphs repeat this paragraph.

About 500 words per page for about five pages, and seven pages are shown here in a planned 36-page issue of Horizons, the bimonthly newslet-

ter of AIAA Houston Section (The American Institute of Aeronautics and Astronautics). Horizons is a free download using PDF format. It is typically 36 pages and 10 to 15 MB per issue. Circulation is about 400 downloads per issue, but in 2007 one issue had more than 30,000 downloads (cover story: The DIRECT Approach). A year or two earlier, one issue had over 40,000 downloads (cover story: Open Source and Free Software). Deadline for inputs for this July / August 2012 issue: August 10, 2012. This issue will be online and published by August 31, 2012. The web site will be www.aiaa-houston.org until June 30, 2012, then we are changing everything and using www.aiaahouston.org. The following paragraphs repeat this paragraph.

(Continued on page 26)



Overview



Ellington Field Joint Reserve Base

- Ellington Field JRB Overview
- Ellington Field JRB Tenants
 - 147th Reconnaissance Wing
 - 1-149th Attack Reconnaissance Battalion
 - U.S. Coast Guard
 - 138th Fighter Wing Det 1
 - 75th Battle Command Training Division
 - Navy Operational Support Center
 - 1st Battalion 23rd Marines
 - Texas State Guard
 - Civil Air Patrol
- Ellington Field JRB Population
- Ellington Field JRB Needs



Everything Ellington

(Continued from page 25)
 About 500 words per page for about five pages, and seven pages are shown here in a planned 36-page issue of Horizons, the bimonthly newsletter of AIAA Houston Section (The American Institute of Aeronautics and Astronautics). Horizons is a free download using PDF format. It is typically 36 pages and 10 to 15 MB per issue. Circulation is about 400 downloads per issue, but in 2007 one issue had more than 30,000 downloads (cover story: The DIRECT Approach). A year or two earlier, one issue had over 40,000 downloads (cover story: Open Source and Free Software). Deadline for inputs for this July / August 2012 issue: August 10, 2012. This issue will be online and publicized by August 31, 2012. The web site will be www.aiaa-houston.org until

June 30, 2012, then we are changing everything and using www.aiaahouston.org. The following paragraphs repeat this paragraph.

About 500 words per page for about five pages, and seven pages are shown here in a planned 36-page issue of Horizons, the bimonthly newsletter of AIAA Houston Section (The American Institute of Aeronautics and Astronautics). Horizons is a free download using PDF format. It is typically 36 pages and 10 to 15 MB per issue. Circulation is about 400 downloads per issue, but in 2007 one issue had more than 30,000 downloads (cover story: The DIRECT Approach). A year or two earlier, one issue had over 40,000 downloads (cover story: Open Source and Free Software). Deadline for inputs for this July / August 2012

issue: August 10, 2012. This issue will be online and publicized by August 31, 2012. The web site will be www.aiaa-houston.org until June 30, 2012, then we are changing everything and using www.aiaahouston.org. The following paragraphs repeat this paragraph.

About 500 words per page for about five pages, and seven pages are shown here in a planned 36-page issue of Horizons, the bimonthly newsletter of AIAA Houston Section (The American Institute of Aeronautics and Astronautics). Horizons is a free download using PDF format. It is typically 36 pages and 10 to 15 MB per issue. Circulation is about 400 downloads per issue, but in 2007 one issue had more than 30,000 downloads (cover story: The DIRECT Approach). A

(Continued on page 27)



147th Reconnaissance Wing Texas Air National Guard

Ellington Field Joint Reserve Base

- **Mission**
 Federal - Provides Combat Support to multiple commands
 State - Disaster response and border protection
- **Capabilities**
 MQ-1B Predator
 Air Support Operations Squadron
 RC-26 Counter Drug
- **Personnel**
 924 (309 Full-time / 615 Part-time)
- **Community Impact**
 \$84 million
- **Needs**
 FAA Approval to Fly in NAS
 JRB Status-Purple Money



(Continued from page 26)
 year or two earlier, one issue had over 40,000 downloads (cover story: Open Source and Free Software). Deadline for inputs for this July / August 2012 issue: August 10, 2012. This issue will be online and publicized by August 31, 2012. The web site will be www.aiaa-houston.org until June 30, 2012, then we are changing everything and using www.aiaahouston.org. The following paragraphs repeat this paragraph.

About 500 words per page for about five pages, and seven pages are shown here in a planned 36-page issue of Horizons, the bimonthly newsletter of AIAA Houston Section (The American Institute of Aeronautics and Astronautics). Horizons is a free download using PDF format. It is typically 36 pages and 10 to 15 MB per issue. Circulation is about 400 downloads per issue, but in 2007 one issue had more than 30,000 downloads (cover story: The DIRECT Approach). A year or two earlier, one issue had over 40,000 downloads (cover story: Open Source and Free Software). Deadline for inputs for this July / August 2012 issue: August 10, 2012. This issue will be online and publicized by August 31, 2012. The web site will be www.aiaa-houston.org until June 30, 2012, then we are changing everything and using www.aiaahouston.org. The following paragraphs repeat this paragraph.

tion is about 400 downloads per issue, but in 2007 one issue had more than 30,000 downloads (cover story: The DIRECT Approach). A year or two earlier, one issue had over 40,000 downloads (cover story: Open Source and Free Software). Deadline for inputs for this July / August 2012 issue: August 10, 2012. This issue will be online and publicized by August 31, 2012. The web site will be www.aiaa-houston.org until June 30, 2012, then we are changing everything and using www.aiaahouston.org. The following paragraphs repeat this paragraph.

About 500 words per page for about five pages, and seven pages are shown here in a planned 36-page issue of Horizons, the bimonthly newsletter of AIAA Houston Section (The American Institute of Aeronautics and Astro-

nautics). Horizons is a free download using PDF format. It is typically 36 pages and 10 to 15 MB per issue. Circulation is about 400 downloads per issue, but in 2007 one issue had more than 30,000 downloads (cover story: The DIRECT Approach). A year or two earlier, one issue had over 40,000 downloads (cover story: Open Source and Free Software). Deadline for inputs for this July / August 2012 issue: August 10, 2012. This issue will be online and publicized by August 31, 2012. The web site will be www.aiaa-houston.org until June 30, 2012, then we are changing everything and using www.aiaahouston.org. The following paragraphs repeat this paragraph.

Everything Ellington

Douglas,

Attached are the two Ellington presentations given to the Bay Area Houston Economic Partnership general membership meeting on May 16 by Mario Diaz (Houston Airport System) and Col. Daniel (Ellington Field JRB). The contact info is:

*Ellington Airport
 Pete Fress, Asst. General Manager
 Houston Airport System
 City of Houston
 713-847-4210*

*Ellington Field Joint Reserve Base
 Col. Jack Daniel
 Texas Air National Guard
 Commander 147th Reconnaissance Wing
 281-929-2222*

I hope this helps with a Horizons article.

*Bob Payne
 Director
 Space Alliance Technology Outreach Program
 Bay Area Houston Economic Partnership
 P.O. Box 58724, Houston, TX
 77258-8724
 832-536-3255 voice
www.bavareahouston.com
www.spacetechsolutions.com*

U.S. AIR FORCE

MQ-1 Predator / MQ-9 Reaper

101

Colonel Jack "Stitch" Daniel, Commander

Ellington Field Joint Reserve Base

Current Events

Current Events

Staying Informed

Staying Informed

AIAA Houston Section events & other events related to aeronautics & astronautics. This July / August 2012 issue of Horizons is scheduled to be online by August 31, 2012. All items are subject to change without notice.

AIAA Houston Section council meetings: email [secretary2012\[at\]aiaahouston.org](mailto:secretary2012@aiaahouston.org)

Time: 5:30 - 6:30 PM usually

Day: First Monday of most months except for holidays.

Location: NASA/JSC Gilruth Center is often used. The room varies.

AIAA National & International Conferences

30 July - 1 August 2012 Atlanta, Georgia
48th AIAA/ASME/SAE/ASEE Joint Propulsion Conference & Exhibit and 10th International Energy Conversion Engineering Conference

2-3 August 2012: Regional Leadership Conference (RLC), Atlanta, Georgia
Venue: Hyatt Regency Atlanta

13 - 16 August 2012, Minneapolis, Minnesota
AIAA Guidance, Navigation and Control and Co-located Conferences

11 - 13 September 2012, Pasadena, California
AIAA Complex Aerospace Systems Exchange

11 - 13 September 2012, Pasadena, California
AIAA SPACE 2012 Conference & Exposition

17 - 19 September 2012, Indianapolis, Indiana
12th AIAA Aviation Technology, Integration, and Operations (ATIO) Conference and 14th AIAA/ISSMO Multidisciplinary Analysis and Optimization Conference

24 - 28 September 2012, Tours, France
18th AIAA/3AF International Space Planes and Hypersonic Systems and Technologies Conference

24 - 28 September 2012, Ft. Walton Beach, Florida
7th AIAA Biennial National Forum on Weapon System Effectiveness

Cranium Cruncher

DR. STEVEN E. EVERETT

Challenge

```
      *7***  
*** ) *****  
     ****  
      ***  
      ***  
      ****  
       ***  
       ****  
        ***  
        ****  
         ***
```

Section News

*Sister Section of AIAA Houston Section since 2007
Jumelée avec AIAA Houston Section depuis 2007*



Association Aéronautique et Astronautique de France (3AF)



ORGANIGRAMME 3AF MP

2012

2013

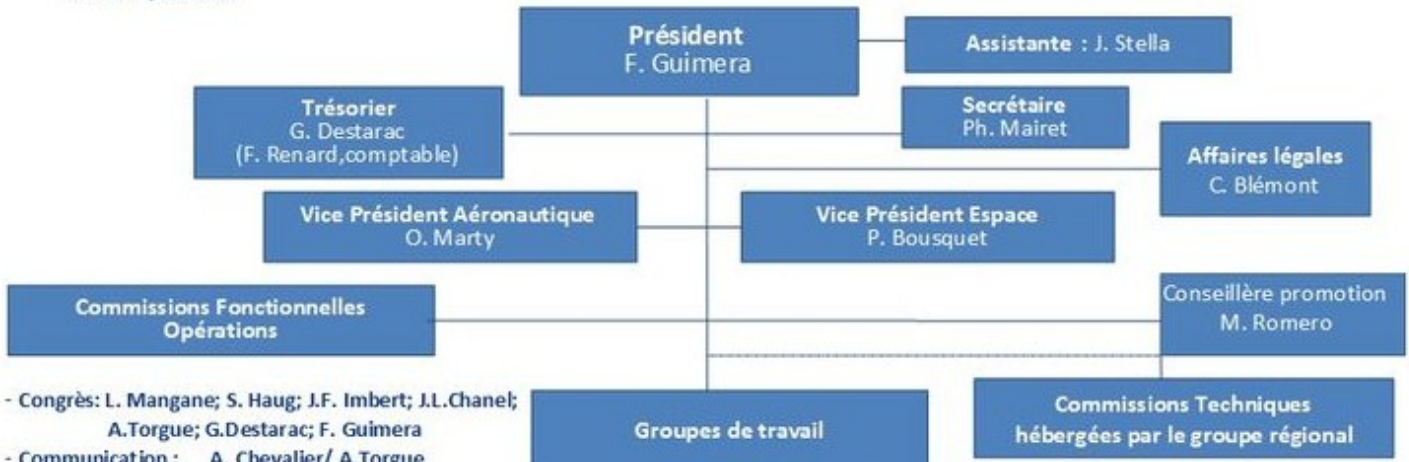

- Congrès: L. Mangane; S. Haug; J.F. Imbert; J.L.Chanel; A.Torgue; G.Destarac; F. Guimera
- Communication : A. Chevalier/ A.Torgue
- Jeunes : M. Biason (C. Romboletti)
- Programmation : O. Marty/ Y.Roncin
- Relations Ecoles & Université:
 - ENAC: B. Lamiscarre
 - ISAE: Y. Gourinat; J.Huet
 - IPSA: A. Torgue (C. Romboletti)
 - UPS: (S. Boyer)
- Relations URISMIP: P. Leparoux
- Relations CDE: J.J Runavot; J.M. Faure
- Relations PME/ PMI: S.Haug; G. Ladier; K. Dijkstra
- Relations TMMA : (F. Renard)
- Site Internet: J.C. Torgue

- Patrimoine (Com. Histoire): G. Destarac
- Tourisme Spatial (Com. Transp. Spatial): (G. Smith)
- Systèmes Embarqués Critiques : G. Ladier
- Observations du Ciel: M. Bonavitacola

- Aviation Civile & Commerciale : F. Guimera
- Aviation Légère & Machines Dérivées : J.L Chanel
- Environnement : TBD
- Exploration et Observation spatiales: M. Rieugnié

The AIAA Houston Section logo is a preliminary version in work as of June 29, 2012.

Section News



The American Institute of Aeronautics and Astronautics (AIAA)

AIAA Houston Section
PO Box 57524
Webster, TX 77598

www.aiaahouston.org

Executive Council
July 01, 2011 - June 30, 2012
www.aiaa-houston.org

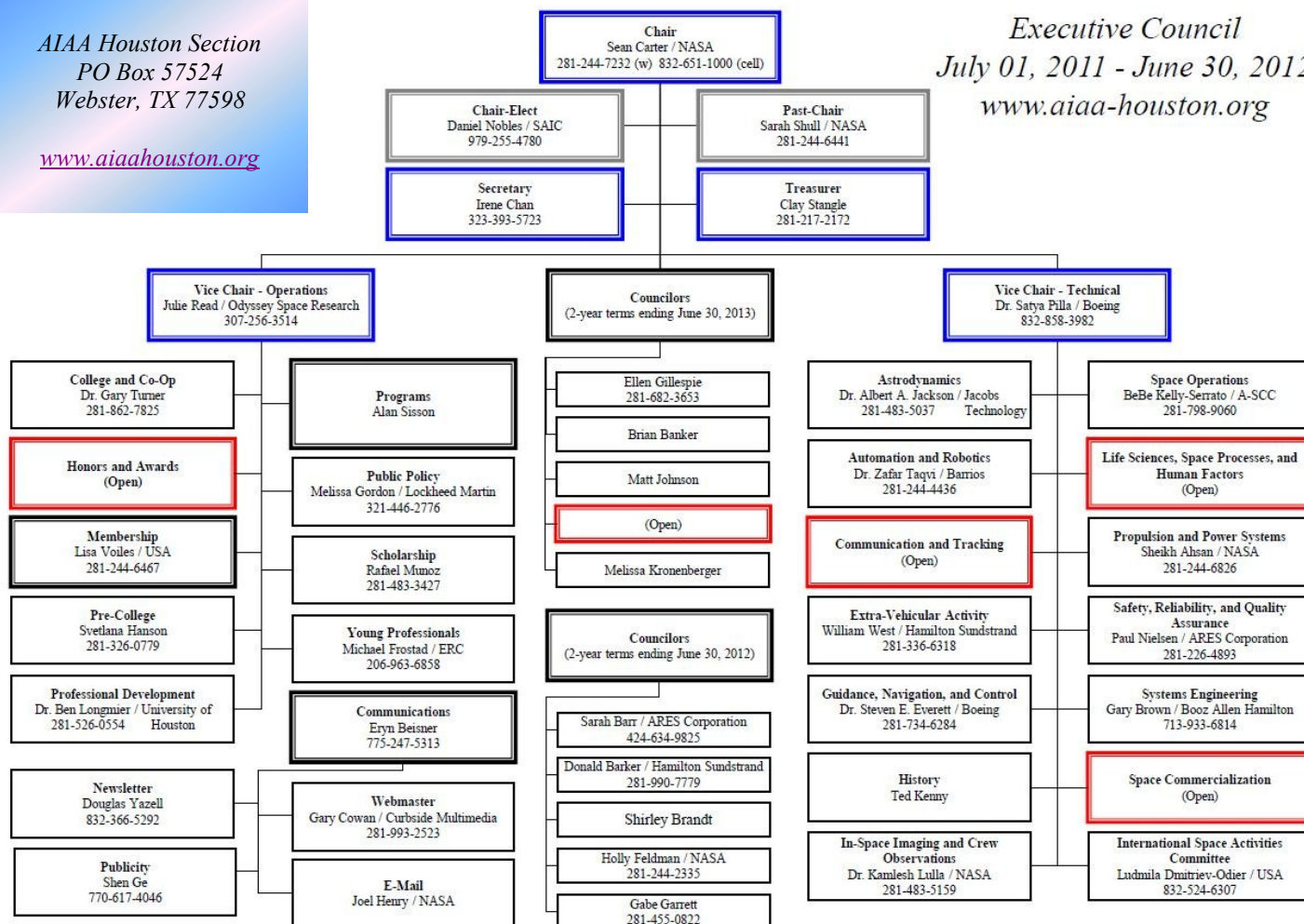

Updated May 13, 2012, Executive Council Voting Members (20) are identified by:

Everything Ellington



AIAA Mission & Vision Statement

The shaping, dynamic force in aerospace - THE forum for innovation, excellence and global leadership. AIAA advances the state of aerospace science, engineering, and technological leadership. Core missions include communications and advocacy, products and programs, membership value, and market and workforce development.

The World's Forum for Aerospace Leadership

Become a member of AIAA

Are you interested in becoming a member of AIAA, or renewing your membership? You can fill out your membership application online at the AIAA national web site: www.aiaa.org. Select the AIAA membership option.